

# PACKAGED GAS / ELECTRIC UNIT 7.5-12.5 TON DIRECT DRIVE LIGHT COMMERCIAL DSG MODELS INSTALLATION INSTRUCTIONS

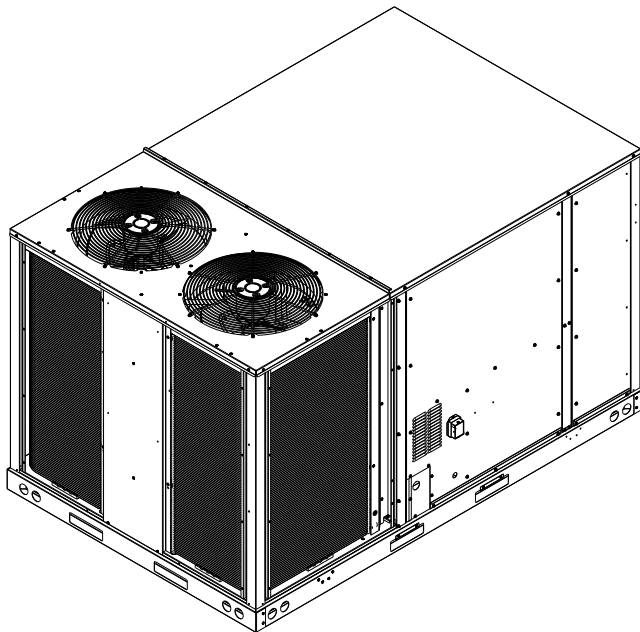

This forced air central unit design complies with requirements embodied in The American National Standard / National Standard of Canada **ANSI Z21.47•CSA-2.3 Gas-fired central furnaces.**

**WARNING**

**ONLY PERSONNEL THAT HAVE BEEN TRAINED TO INSTALL, ADJUST, SERVICE, MAINTENANCE OR REPAIR (HEREINAFTER, "SERVICE") THE EQUIPMENT SPECIFIED IN THIS MANUAL SHOULD SERVICE THE EQUIPMENT.**

**THIS EQUIPMENT IS NOT INTENDED FOR USE BY PERSONS (INCLUDING CHILDREN) WITH REDUCED PHYSICAL, SENSORY OR MENTAL CAPACITIES, OR LACK OF EXPERIENCE AND KNOWLEDGE, UNLESS THEY HAVE BEEN GIVEN SUPERVISION OR INSTRUCTION CONCERNING USE OF THE APPLIANCE BY A PERSON RESPONSIBLE FOR THEIR SAFETY.**

**CHILDREN SHOULD BE SUPERVISED TO ENSURE THAT THEY DO NOT PLAY WITH THE EQUIPMENT.**

**THE MANUFACTURER WILL NOT BE RESPONSIBLE FOR ANY INJURY OR PROPERTY DAMAGE ARISING FROM IMPROPER SUPERVISION, SERVICE OR SERVICE PROCEDURES. IF YOU SERVICE THIS UNIT, YOU ASSUME RESPONSIBILITY FOR ANY INJURY OR PROPERTY DAMAGE WHICH MAY RESULT. IN ADDITION, IN JURISDICTIONS THAT REQUIRE ONE OR MORE LICENSES TO SERVICE THE EQUIPMENT SPECIFIED IN THIS MANUAL, ONLY LICENSED PERSONNEL SHOULD SERVICE THE EQUIPMENT. IMPROPER SUPERVISION, INSTALLATION, ADJUSTMENT, SERVICING, MAINTENANCE OR REPAIR OF THE EQUIPMENT SPECIFIED IN THIS MANUAL, OR ATTEMPTING TO INSTALL, ADJUST, SERVICE OR REPAIR THE EQUIPMENT SPECIFIED IN THIS MANUAL WITHOUT PROPER SUPERVISION OR TRAINING MAY RESULT IN PRODUCT DAMAGE, PROPERTY DAMAGE, PERSONAL INJURY OR DEATH.**

**WARNING**

**DO NOT BYPASS SAFETY DEVICES**

Our continuing commitment to quality products may mean a change in specifications without notice.

©2024 **DAIKIN COMFORT TECHNOLOGIES MANUFACTURING, L.P.**

19001 Kermier Rd., Waller, TX 77484

[www.daikincomfort.com](http://www.daikincomfort.com)



## INDEX

|   |           |
|---|-----------|
| <b>SAFETY INSTRUCTIONS</b> .....                | <b>2</b>  |
| <b>REPLACEMENT PARTS</b> .....                  | <b>2</b>  |
| <b>GENERAL INFORMATION</b> .....                | <b>6</b>  |
| <b>CLEARANCES</b> .....                         | <b>9</b>  |
| <b>ROOF CURB POST-INSTALLATION CHECKS</b> ..... | <b>9</b>  |
| <b>ROOF TOP DUCT CONNECTIONS</b> .....          | <b>9</b>  |
| <b>RIGGING DETAILS</b> .....                    | <b>10</b> |
| <b>WEIGHTS AND CENTER OF GRAVITY</b> .....      | <b>11</b> |
| <b>ELECTRICAL WIRING</b> .....                  | <b>11</b> |
| <b>GAS SUPPLY PIPING</b> .....                  | <b>14</b> |
| <b>PROPANE GAS INSTALLATIONS</b> .....          | <b>16</b> |
| <b>CIRCULATING AIR AND FILTERS</b> .....        | <b>17</b> |
| <b>VENTING</b> .....                            | <b>17</b> |
| <b>CONDENSATE DRAIN CONNECTION</b> .....        | <b>17</b> |
| <b>STARTUP, ADJUSTMENTS, AND CHECKS</b> .....   | <b>18</b> |
| <b>AIR FLOW ADJUSTMENTS</b> .....               | <b>19</b> |
| <b>GAS SYSTEM CHECK</b> .....                   | <b>21</b> |
| <b>NORMAL SEQUENCE OF OPERATION</b> .....       | <b>24</b> |
| <b>MAINTENANCE</b> .....                        | <b>28</b> |
| <b>TROUBLESHOOTING</b> .....                    | <b>30</b> |
| <b>APPENDIX A BLOWER PERFORMANCE DATA</b> ..... | <b>33</b> |
| <b>APPENDIX B ELECTRICAL DATA</b> .....         | <b>69</b> |
| <b>APPENDIX C UNIT DIMENSIONS</b> .....         | <b>73</b> |
| <b>APPENDIX D MIN-MAX AIRFLOW</b> .....         | <b>74</b> |
| <b>WIRING DIAGRAM</b> .....                     | <b>75</b> |
| <b>START-UP CHECKLIST</b> .....                 | <b>76</b> |

## REPLACEMENT PARTS

### ORDERING PARTS

When reporting shortages or damages, or ordering repair parts, give the complete unit model and serial numbers as stamped on the unit's nameplate.  
<https://www.goodmanmfg.com/logistics-feedback>"Feedback (goodmanmfg.com)

Refrigerant sensors for refrigerant detection systems shall only be replaced with sensors specified by the manufacturer.

Replacement parts for this appliance are available through your contractor or local distributor. Your nearest distributor can be located online at [www.daikinac.com](http://www.daikinac.com) or by contacting:

### EQUIPMENT SUPPORT

**Daikin Comfort Technologies Manufacturing L.P.**  
**19001 Kermier Road**  
**Waller, Texas 77484**  
**855-770-5678**

## SAFETY INSTRUCTIONS



**RECOGNIZE THIS SYMBOL AS A SAFETY PRECAUTION.**

These installation instructions cover the outdoor installation of single package heating and cooling units. See the Specification Sheet applicable to your model for information regarding accessories.

**\*NOTE: PLEASE CONTACT YOUR DISTRIBUTOR OR OUR WEBSITE FOR THE APPLICABLE SPECIFICATION SHEET REFERRED TO IN THIS MANUAL.**

### TO THE INSTALLER

Before installing this unit, please read this manual to familiarize yourself on the specific items which must be adhered to, including maximum external static pressure to unit, air temperature rise, minimum or maximum CFM and motor speed connections.

Keep this literature in a safe place for future reference.



### WARNING

**DO NOT USE MEANS TO ACCELERATE DEFROSTING PROCESS OR TO CLEAN, OTHER THAN THOSE RECOMMENDED BY THE MANUFACTURER.**

**THE APPLIANCE SHALL BE STORED IN A ROOM WITHOUT CONTINUOUSLY OPERATING IGNITION SOURCES (FOR EXAMPLE: OPEN FLAMES, AN OPERATING GAS APPLIANCE OR AN OPERATING ELECTRIC HEATER.)**

**DO NOT PIERCE OR BURN.**

**BE AWARE THAT REFRIGERANTS MAY NOT CONTAIN AN ODOUR.**



### WARNING

ONLY AUXILIARY DEVICES APPROVED BY THE APPLIANCE MANUFACTURER OR DECLARED SUITABLE WITH THE REFRIGERANT SHALL BE INSTALLED IN CONNECTING DUCTWORK.



### WARNING

AUXILIARY DEVICES WHICH MAY BE A POTENTIAL IGNITION SOURCE SHALL NOT BE INSTALLED IN THE DUCT WORK. EXAMPLES OF SUCH POTENTIAL IGNITION SOURCES ARE HOT SURFACES WITH A TEMPERATURE EXCEEDING 700°C AND ELECTRIC SWITCHING DEVICES.



### WARNING

“LEAK DETECTION SYSTEM INSTALLED. UNIT MUST BE POWERED EXCEPT FOR SERVICE.”



### WARNING

“THIS UNIT IS EQUIPPED WITH ELECTICALLY POWERED SAFETY MEASURES. TO BE EFFECTIVE, THE UNIT MUST BE ELECTRICALLY POWERED AT ALL TIMES AFTER INSTALLATION, OTHER THAN WHEN SERVICING.”



### WARNING

IF THE INFORMATION IN THESE INSTRUCTIONS IS NOT FOLLOWED EXACTLY, A FIRE OR EXPLOSION MAY RESULT CAUSING PROPERTY DAMAGE, PERSONAL INJURY OR LOSS OF LIFE.

- DO NOT STORE OR USE GASOLINE OR OTHER FLAMMABLE VAPORS AND LIQUIDS IN THE VICINITY OF THIS OR ANY OTHER APPLIANCE.

- WHAT TO DO IF YOU SMELL GAS:

- DO NOT TRY TO LIGHT ANY APPLIANCE.
- DO NOT TOUCH ANY ELECTRICAL SWITCH; DO NOT USE ANY PHONE IN YOUR BUILDING.
- IMMEDIATELY CALL YOUR GAS SUPPLIER FROM A NEIGHBOR’S PHONE. FOLLOW THE GAS SUPPLIER’S INSTRUCTIONS. IF YOU CANNOT REACH YOUR GAS SUPPLIER, CALL THE FIRE DEPARTMENT.

- INSTALLATION AND SERVICE MUST BE PERFORMED BY A QUALIFIED INSTALLER, SERVICE AGENCY OR THE GAS SUPPLIER.



### WARNING

#### FIRE OR EXPLOSION HAZARD

Failure to follow the safety warnings exactly could result in serious injury, death or property damage.

Never test for gas leaks with an open flame. Use a commercially available soap solution made specifically for the detection of leaks to check all connections. A fire or explosion may result causing property damage, personal injury or loss of life.



### AVERTISSEMENT

#### RISQUE D’INCENDIE OU D’EXPLOSION

Si les consignes de sécurité ne sont pas suivies à la lettre, cela peut entraîner la mort, de graves blessures ou des dommages matériels.

Ne jamais vérifier la présence de fuites de gaz au moyen d’une flamme nue. Vérifier tous les raccords en utilisant une solution savonneuse commerciale conçue spécialement pour la détection de fuites. Un incendie ou une explosion risque de se produire, ce qui peut entraîner la mort, des blessures ou des dommages matériels.



### WARNING

TO PREVENT THE RISK OF PROPERTY DAMAGE, PERSONAL INJURY, OR DEATH, DO NOT STORE COMBUSTIBLE MATERIALS OR USE GASOLINE OR OTHER FLAMMABLE LIQUIDS OR VAPORS IN THE VICINITY OF THIS APPLIANCE.



### WARNING

SHOULD OVERHEATING OCCUR OR THE GAS SUPPLY FAIL TO SHUT OFF, TURN OFF THE MANUAL GAS SHUTOFF VALVE EXTERNAL TO THE FURNACE BEFORE TURNING OFF THE ELECTRICAL SUPPLY.



### CAUTION

SHEET METAL PARTS, SCREWS, CLIPS AND SIMILAR ITEMS INHERENTLY HAVE SHARP EDGES, AND IT IS NECESSARY THAT THE INSTALLER AND SERVICE PERSONNEL EXERCISE CAUTION.



### WARNING

DO NOT CONNECT TO OR USE ANY DEVICE THAT IS NOT DESIGN CERTIFIED BY THE MANUFACTURER FOR USE WITH THIS UNIT. SERIOUS PROPERTY DAMAGE, PERSONAL INJURY, REDUCED UNIT PERFORMANCE AND/ OR HAZARDOUS CONDITIONS MAY RESULT FROM THE USE OF SUCH NON-APPROVED DEVICES.



**WARNING**

**TO AVOID PROPERTY DAMAGE, PERSONAL INJURY OR DEATH, DO NOT USE THIS UNIT IF ANY PART HAS BEEN UNDER WATER. IMMEDIATELY CALL A QUALIFIED SERVICE TECHNICIAN TO INSPECT THE FURNACE AND TO REPLACE ANY PART OF THE CONTROL SYSTEM AND ANY GAS CONTROL HAVING BEEN UNDER WATER.**



**WARNING**

**THIS UNIT MUST NOT BE USED AS A “CONSTRUCTION HEATER” DURING THE FINISHING PHASES OF CONSTRUCTION ON A NEW STRUCTURE. THIS TYPE OF USE MAY RESULT IN PREMATURE FAILURE OF THE UNIT DUE TO EXTREMELY LOW RETURN AIR TEMPERATURE AND EXPOSURE TO CORROSIVE OR VERY DIRTY ATMOSPHERES.**



**WARNING**

**HIGH VOLTAGE!  
DISCONNECT ALL POWER BEFORE SERVICING OR INSTALLING THIS UNIT. MULTIPLE POWER SOURCES MAY BE PRESENT. FAILURE TO DO SO MAY CAUSE PROPERTY DAMAGE, PERSONAL INJURY OR DEATH.**



**WARNING**

**DO NOT OPERATE THE COMPRESSOR(S) WITHOUT THE TERMINAL PLUG FULLY ENGAGED OR THE TERMINAL COVER PROPERLY INSTALLED.**



**WARNING**

**A TRIPPED CIRCUIT BREAKER OR BLOWN FUSE MAY INDICATE THAT AN ELECTRICAL PROBLEM EXISTS. DO NOT RESET A CIRCUIT BREAKER OR REPLACE FUSES WITHOUT FIRST PERFORMING THOROUGH ELECTRICAL TROUBLESHOOTING AND TESTING PROCEDURES.**



**WARNING**

**PRIOR TO SERVICING THE UNIT OR REMOVING THE COMPRESSOR TERMINAL PLUG OR TERMINAL COVER, DISCONNECT ALL ELECTRICAL POWER FROM THE UNIT. MULTIPLE POWER SOURCES MAY BE PRESENT.**



**WARNING**

**CARBON MONOXIDE POISONING HAZARD**

Failure to follow the steps outlined below for each appliance connected to the venting system being placed into operation could result in carbon monoxide poisoning or death.

The following steps shall be followed with each appliance connected to the venting system placed in operation, while any other appliances connected to the venting system are not in operation:

1. Seal any unused openings in the venting system.
2. Inspect the venting system for proper size and horizontal pitch, as required by the National Fuel Gas Code, ANSI Z223.1 or the Natural Gas and Propane Installation Code, CSA B149.1-15 and these instructions. Determine that there is no blockage or restriction, leakage, corrosion and other deficiencies which could cause an unsafe condition.
3. As far as practical, close all building doors and windows and all doors between the space in which the appliance(s) connected to the venting system are located and other spaces of the building.
4. Close fireplace dampers.
5. Turn on clothes dryers and any appliance not connected to the venting system. Turn on any exhaust fans, such as range hoods and bathroom exhausts, so they shall operate at maximum speed. Do not operate a summer exhaust fan.
6. Follow the lighting instructions. Place the appliance being inspected in operation. Adjust thermostat so appliance shall operate continuously.
7. Test for spillage from draft hood appliances at the draft hood relief opening after 5 minutes of main burner operation. Use the flame of a match or candle.
8. If improper venting is observed during any of the above tests, the venting system must be corrected in accordance with the National Fuel Gas Code ANSI Z223.1/NFPA 54 and/or National Gas and Propane Installation Code CSA B149.1-15.
9. After it has been determined that each appliance connected to the venting system properly vents when tested as outlined above, return doors, windows, exhaust fans, fireplace dampers and any other gas burning appliance to their previous conditions of use.



## AVERTISSEMENT

### RISQUE D'INTOXICATION AU MONOXYDE DE CARBONE

Si les étapes décrites ci-dessous ne sont pas suivies pour chacun des appareils raccordés au système de ventilation au moment de sa mise en marche, cela peut entraîner une intoxication au monoxyde de carbone ou la mort. Les étapes suivantes doivent être suivies pour chacun des appareils raccordés au système de ventilation au moment de sa mise en marche, alors que tous les autres appareils raccordés au système de ventilation ne sont pas en marche :

- 1) Sceller toutes les ouvertures inutilisées du système de ventilation.
- 2) Inspecter le système de ventilation afin de vérifier si la taille et l'inclinaison par rapport à l'horizontale sont conformes aux exigences du National Fuel Gas Code, ANSI Z223.1/NFPA 54 ou du Code d'installation du gaz naturel et du propane, CSA B149.1 et à ces instructions. Vérifier qu'il n'y a pas d'obstruction ou de restriction, de fuite, de corrosion et d'autres problèmes qui pourraient entraîner une situation dangereuse.
- 3) Si possible, fermer toutes les portes et fenêtres du bâtiment ainsi que toutes les portes séparant l'endroit où se trouvent les appareils raccordés au système de ventilation et les autres zones du bâtiment.
- 4) Fermer le registre des foyers.
- 5) Mettre les sècheuses en marche ainsi que tous les autres appareils qui ne sont pas raccordés au système de ventilation. Mettre en marche tous les ventilateurs de tirage, comme celui des hottes de cuisine et des salles de bains, et les régler à la puissance maximale. Ne pas mettre en marche les ventilateurs d'été.
- 6) Suivre les instructions d'allumage. Mettre en marche l'appareil soumis à l'inspection. Régler le thermostat de manière à ce que l'appareil fonctionne en continu.
- 7) Vérifier la présence de fuite au niveau de l'ouverture du coupe-tirage des appareils qui en sont dotés après 5 minutes de fonctionnement du brûleur principal. Utiliser la flamme d'une allumette ou d'une bougie.
- 8) Si un problème de ventilation est observé pendant l'un des essais décrits ci-dessus, des correctifs doivent être apportés au système de ventilation conformément au National Fuel Gas Code, ANSI Z223.1/NFPA 54 et (ou) au Code d'installation du gaz naturel et du propane, CSA B149.1.
- 9) Une fois qu'il a été déterminé que chaque appareil raccordé au système de ventilation fonctionne correctement au moyen des essais décrits ci-dessus, les portes, les fenêtres, les ventilateurs, les registres de foyer et tous les autres appareils de combustion alimentés au gaz doivent être remis dans leur état initial.



## DANGER PELIGRO

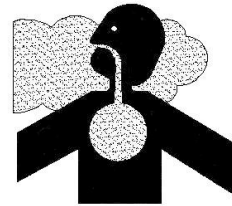

### CARBON MONOXIDE POISONING HAZARD

Special Warning for Installation of Furnace or Air Handling Units in Enclosed Areas such as Garages, Utility Rooms or Parking Areas

Carbon monoxide producing devices (such as automobiles, space heater, gas water heater, etc.) should not be operated in enclosed areas such as unventilated garages, utility rooms or parking areas because of the danger of carbon monoxide (CO) poisoning resulting from the exhaust emissions. If a furnace or air handler is installed in an enclosed area such as a garage, utility room or parking area and a carbon monoxide producing device is operated therein, there must be adequate, direct outside ventilation.

This ventilation is necessary to avoid the danger of CO poisoning which can occur if a carbon monoxide producing device continues to operate in the enclosed area. Carbon monoxide emissions can be (re)circulated throughout the structure if the furnace or air handler is operating in any mode.

CO can cause serious illness including permanent brain damage or death.

B10259-216

### RIESGO DE INTOXICACIÓN POR MONÓXIDO DE CARBONO

Advertencia especial para la instalación de calentadores ó manejadoras de aire en áreas cerradas como estacionamientos ó cuartos de servicio.

Los equipos ó aparatos que producen monóxido de carbono (tal como automóvil, calentador de gas, calentador de agua por medio de gas, etc) no deben ser operados en áreas cerradas debido al riesgo de envenenamiento por monóxido de carbono (CO) que resulta de las emisiones de gases de combustión. Si el equipo ó aparato se opera en dichas áreas, debe existir una adecuada ventilación directa al exterior.

Esta ventilación es necesaria para evitar el peligro de envenenamiento por CO, que puede ocurrir si un dispositivo que produce monóxido de carbono sigue operando en el lugar cerrado.

Las emisiones de monóxido de carbono pueden circular a través del aparato cuando se opera en cualquier modo.

El monóxido de carbono puede causar enfermedades severas como daño cerebral permanente ó muerte.

B10259-216

### RISQUE D'EMPOISONNEMENT AU MONOXYDE DE CARBONE

Avertissement special au sujet de l'installation d'appareils de chauffage ou de traitement d'air dans des endroits clos, tels les garages, les locaux d'entretien et les stationnements.

Évitez de mettre en marche les appareils produisant du monoxyde de carbone (tels que les automobile, les appareils de chauffage autonome, etc.) dans des endroits non ventilés tels que les d'empoisonnement au monoxyde de carbone. Si vous devez faire fonctionner ces appareils dans un endroit clos, assurez-vous qu'il y ait une ventilation directe provenant de l'extérieur.

Cette ventilation est nécessaire pour éviter le danger d'intoxication au CO pouvant survenir si un appareil produisant du monoxyde de carbone continue de fonctionner au sein de la zone confinée.

Les émissions de monoxyde de carbone peuvent être recirculées dans les endroits clos, si l'appareil de chauffage ou de traitement d'air sont en marche.

Le monoxyde de carbone peut causer des maladies graves telles que des dommages permanents au cerveau et même la mort.

B10259-216

## GENERAL INFORMATION



### WARNING

**TO PREVENT PROPERTY DAMAGE, PERSONAL INJURY OR DEATH, DUE TO FIRE, EXPLOSIONS, SMOKE, SOOT, CONDENSATION, ELECTRIC SHOCK OR CARBON MONOXIDE, THIS UNIT MUST BE PROPERLY INSTALLED, REPAIRED, OPERATED, AND MAINTAINED.**

**This unit is approved for outdoor installation ONLY. Not accessible to the general public.** Rated performance is achieved after 20 hours of operation. Rated performance is delivered at the specified airflow. See outdoor unit specification sheet for split system models or product specification sheet for packaged and light commercial models. Specification sheets can be found at [www.daikinac.com](http://www.daikinac.com) for Daikin brand products. Within the website, please select the residential or commercial products menu and then select the submenu for the type of product to be installed, such as air conditioners or heat pumps, to access a list of product pages that each contain links to that model's specification sheet.

To assure that your unit operates safely and efficiently, it must be installed, operated, and maintained in accordance with these installation and operating instructions, and all local building codes and ordinances, or in their absence, with the latest edition of the National Fuel Gas Code NFPA54/ANSI Z223.1 and National Standard of Canada CAN/CSA B149 Installation Codes.

### QUALIFICATION OF WORKERS

Personnel must be certified to service, work, and/or repair units with FLAMMABLE REFRIGERANTS. A certificate should document the competence and qualification achieved through training that included the substance of the following:

- Information about the explosion potential of FLAMMABLE REFRIGERANTS to show that flammables may be dangerous when handled without care.
- Information about POTENTIAL IGNITION SOURCES, especially those that are not obvious, such as lighters, light switches, vacuum cleaners, electric heaters.
- Information about the different safety concepts, including ventilated and unventilated areas.
- Information about refrigerant detectors, including function, operation, and service measures.
- Information about the concept of sealed components and sealed enclosures according to IEC 60079-15:2010.
- Information about the correct working procedures, including commissioning, maintenance, repair, decommissioning, and disposal procedures.

### EPA REGULATIONS

**IMPORTANT: THE UNITED STATES ENVIRONMENTAL PROTECTION AGENCY (EPA) HAS ISSUED VARIOUS REGULATIONS REGARDING THE INTRODUCTION AND DISPOSAL OF REFRIGERANTS IN THIS UNIT. FAILURE TO FOLLOW THESE REGULATIONS MAY HARM THE ENVIRONMENT AND CAN LEAD TO THE IMPOSITION OF SUBSTANTIAL FINES. BECAUSE REGULATIONS MAY VARY DUE TO PASSAGE OF NEW LAWS, WE SUGGEST A CERTIFIED TECHNICIAN PERFORM ANY WORK DONE ON THIS UNIT. SHOULD YOU HAVE ANY QUESTIONS PLEASE CONTACT THE LOCAL OFFICE OF THE EPA.**

### NATIONAL CODES

This product is designed and manufactured to permit installation in accordance with National Codes. It is the installer's responsibility to install the product in accordance with National Codes and/or prevailing local codes and regulations.

The heating and cooling capacities of the unit should be greater than or equal to the design heating and cooling loads of the area to be conditioned. The loads should be calculated by an approved method or in accordance with ASHRAE Guide or Manual J - Load Calculations published by the Air Conditioning Contractors of America.

Obtain from:

American National Standards Institute  
[www.ansi.org](http://www.ansi.org)

System design and installation should also, where applicable, follow information presented in accepted industry guides such as the ASHRAE Handbooks. The manufacturer assumes no responsibility for equipment installed in violation of any code or regulation. The mechanical installation of the packaged roof top units consists of making final connections between the unit and building services; supply and return duct connections; and drain connections (if required). The internal systems of the unit are completely factory-installed and tested prior to shipment.

Units are generally installed on a steel roof mounting curb assembly which has been shipped to the job site for installation on the roof structure prior to the arrival of the unit. The model number shown on the unit's identification plate identifies the various components of the unit such as refrigeration tonnage, heating input and voltage.

Carefully inspect the unit for damage including damage to the cabinetry. Any bolts or screws which may have loosened in transit must be re-tightened.

In the event of damage, the receiver should:

1. Make notation on delivery receipt of any visible damage to shipment or container.
2. Notify the carrier promptly and request an inspection.
3. In case of concealed damage, carrier should be notified as soon as possible-preferably within 5 days.
4. File the claim with the following supporting documents:

- a. Original Bill of Lading, certified copy, or indemnity bond.
- b. Original paid freight bill or indemnity in lieu thereof.
- c. Original invoice or certified copy thereof, showing trade and other discounts or reductions.
- d. Copy of the inspection report issued by the carrier representative at the time damage is reported to the carrier. The carrier is responsible for making prompt inspection of damage and for a thorough investigation of each claim. The distributor or manufacturer will not accept claims from dealers for transportation damage.

**NOTE: WHEN INSPECTING THE UNIT FOR TRANSPORTATION DAMAGE, REMOVE ALL PACKAGING MATERIALS. RECYCLE OR DISPOSE OF THE PACKAGING MATERIAL ACCORDING TO LOCAL CODES.**

**PRE-INSTALLATION CHECKS**

Carefully read all instructions for the installation prior to installing unit. Ensure each step or procedure is understood and any special considerations are taken into account before starting installation. Assemble all tools, hardware and supplies needed to complete the installation. Some items may need to be purchased locally.

**WIRING**

Check that wiring will not be subject to wear, corrosion, excessive pressure, vibration, sharp edges or any other adverse environmental effects. The check shall also take into account the effects of aging or continual vibration from sources such as compressors or fans.

**Detection of flammable refrigerants**

“Under no circumstances shall potential sources of ignition be used in the searching for or detection of refrigerant leaks. A halide torch (or any other detector using a naked flame) shall not be used.

The following leak detection methods are deemed acceptable for all refrigerant systems.

Electronic leak detectors may be used to detect refrigerant leaks but, in the case of FLAMMABLE REFRIGERANTS, the sensitivity may not be adequate, or may need re-calibration. (Detection equipment shall be calibrated in a refrigerant-free area.)

Ensure that the detector is not a potential source of ignition and is suitable for the refrigerant used. Leak detection equipment shall be set at a percentage of the LFL of the refrigerant and shall be calibrated to the refrigerant employed, and the appropriate percentage of gas (25 % maximum) is confirmed.

Leak detection fluids are also suitable for use with most refrigerants but the use of detergents containing chlorine shall be avoided as the chlorine may react with the refrigerant and corrode the copper pipe-work.

If a leak is suspected, all naked flames shall be removed/extinguished.

If a leakage of refrigerant is found which requires brazing, all of the refrigerant shall be recovered from the system, or isolated (by means of shut off valves) in a part of the system remote from the leak.

|   |
|---|
|  <b>WARNING</b>  |
| <p><b>TO PREVENT POSSIBLE EQUIPMENT DAMAGE, PROPERTY DAMAGE, PERSONAL INJURY OR DEATH, THE FOLLOWING BULLET POINTS MUST BE OBSERVED WHEN INSTALLING THE UNIT.</b></p> |



**IMPORTANT NOTE: REMOVE WOOD SHIPPING RAILS PRIOR TO INSTALLATION OF THE UNIT.**

**NOTE: UNITS MAY BE INSTALLED IN HEAVY SNOW CLIMATES. ENSURE NO SNOW OBSTRUCTS OR COVERS THE UNIT, AS IT MAY AFFECT PERFORMANCE. REGULARLY CHECK FOR SNOW BUILDUP.**

**ALL INSTALLATIONS:**

**IMPORTANT NOTE: UNIT SHOULD BE ENERGIZED 24 HOURS PRIOR TO COMPRESSOR START UP TO ENSURE CRANKCASE HEATER HAS SUFFICIENTLY WARMED THE COMPRESSORS. COMPRESSOR DAMAGE MAY OCCUR IF THIS STEP IS NOT FOLLOWED.**

**NOTE: APPLIANCE IS SHIPPED FROM FACTORY FOR VERTICAL DUCT APPLICATION.**

|  |
|--|
|  <b>WARNING</b>                                 |
| <p><b>THE APPLIANCE SHALL BE INSTALLED. OPERATED AND STORED IN A ROOM WITH A FLOOR AREA NOT LESS THAN THE MINIMUM ROOM AREA.</b></p> |
|   |
| <p><b>≥ 15.3 m<sup>2</sup></b><br/><b>164.7 ft<sup>2</sup></b></p>   |

Proper installation of the unit ensures trouble-free operation. Improper installation can result in problems ranging from noisy operation to property or equipment damages, dangerous conditions that could result in injury or personal property damage and that are not covered by the warranty. Give this booklet to the user and explain it's provisions. The user should retain these instructions for future reference.

- For proper flame pattern within the heat exchanger and proper condensate drainage, the unit must be mounted level.
- The flue outlet must be at least 12 inches from any opening through which flue gases could enter a building, and at least three feet above any forced air inlet located within ten feet. The economizer/manual fresh air intake/motorized fresh air intake and combustion air inlet mounted on the unit are not affected by this restriction.
- To avoid possible corrosion of the heat exchanger, do not locate the unit in an area where the outdoor air (i.e. combustion air for the unit) will be frequently contaminated by compounds containing chlorine or fluorine. Common sources of such compounds include swimming pool chemicals and chlorine bleaches, paint stripper, adhesives, paints, varnishes, sealers, waxes (which are not yet dried) and solvents used during construction and remodeling. Various commercial and industrial processes may also be sources of chlorine/fluorine compounds.
- The unit shall not be connected to a chimney flue serving a separate appliance designed to burn solid fuel.
- To avoid possible illness or death of the building occupants, do NOT locate outside air intake device (economizer, manual fresh air intake, motorized fresh air intake) too close to an exhaust outlet, gas vent termination, or plumbing vent outlet. For specific distances required, consult local codes.
- Allow minimum clearances from the enclosure for fire protection, proper operation, and service access (see unit clearances). These clearances must be permanently maintained.
- The combustion air inlet and flue outlet on the unit must never be obstructed. If used, do not allow the economizer/manual fresh air damper/ motorized fresh air damper to become blocked by snow or debris. In some climates or locations, it may be necessary to elevate the unit to avoid these problems.
- When the unit is heating, the temperature of the return air entering the unit must be a minimum of 55° F.

#### **GROUND LEVEL INSTALLATIONS ONLY:**

- When the unit is installed on the ground adjacent to the building, a level concrete (or equal) base is recommended. Prepare a base that is 3" larger than the package unit footprint and a minimum of 3" thick.
- The base should also be located where no runoff of water from higher ground can collect in the unit.

#### **ROOF TOP INSTALLATIONS ONLY:**

- To avoid possible property damage or personal injury, the roof must have sufficient structural strength to carry the weight of the unit(s) and snow or water loads as required by local codes. Consult a structural engineer to determine the weight capabilities of the roof.
- The unit may be installed directly on wood floors or on Class A, Class B, or Class C roof covering material.
- To avoid possible personal injury, a safe, flat surface for service personnel should be provided.
- As indicated on the unit data plate, a minimum clearance of 36" to any combustible material is required on the furnace access side of the unit. All combustible materials must be kept out of this area.
- This 36" clearance must also be maintained to insure proper combustion air and flue gas flow. The combustion air intake and furnace flue discharge must not be blocked for any reason, including blockage by snow.
- Adequate clearances from the furnace flue discharge to any adjacent public walkways, adjacent buildings, building openings or openable windows must be maintained in accordance with the latest edition of the National Fuel Gas Code ANSI Z223.1/NFPA 54.
- Minimum horizontal clearance of 48" from the furnace flue discharge to any electric meters, gas meters, regulators and relief equipment is required.

#### **UNIT PRECAUTIONS**

- Do not stand or walk on the unit.
- Do not drill holes anywhere in panels or in the base frame of the unit except where indicated. Unit access panels provide structural support.
- Do not remove any access panels until unit has been installed on roof curb or field supplied structure.
- Do not roll unit across finished roof without prior approval of owner or architect.
- Do not skid or slide on any surface as this may damage unit base. The unit must be stored on a flat, level surface. Protect the condenser coil because it is easily damaged.

#### **ROOF CURB INSTALLATIONS ONLY:**

Curb installations must comply with local codes and should be done in accordance with the established guidelines of the National Roofing Contractors Association.

Proper unit installation requires that the roof curb be firmly and permanently attached to the roof structure. Check for adequate fastening method prior to setting the unit on the curb.

Full perimeter roof curbs are available from the factory and are shipped unassembled. Field assembly, squaring, leveling and mounting on the roof structure are the responsibility of the installing contractor. All required hardware necessary for the assembly of the sheet metal curb is included in the curb accessory.





## WARNING

**TO PREVENT POSSIBLE EQUIPMENT DAMAGE, PROPERTY DAMAGE, PERSONAL INJURY OR DEATH, THE FOLLOWING BULLET POINTS MUST BE OBSERVED WHEN INSTALLING THE UNIT.**

- Sufficient structural support must be determined prior to locating and mounting the curb and package unit.
- Ductwork must be constructed using industry guidelines. The duct work must be placed into the roof curb before mounting the package unit. Our full perimeter curbs include duct connection frames to be assembled with the curb. Cantilevered type curbs are not available from the factory.
- Curb insulation, cant strips, flashing and general roofing material are furnished by the contractor.
- The curbs must be supported on parallel sides by roof members.
- The roof members must not penetrate supply and return duct opening areas as damage to the unit might occur.

**NOTE: THE UNIT AND CURB ACCESSORIES ARE DESIGNED TO ALLOW VERTICAL DUCT INSTALLATION BEFORE UNIT PLACEMENT. DUCT INSTALLATION AFTER UNIT PLACEMENT IS NOT RECOMMENDED.**



## CAUTION

**ALL CURBS LOOK SIMILAR. TO AVOID INCORRECT CURB POSITIONING, CHECK JOB PLANS CAREFULLY AND VERIFY MARKINGS ON CURB ASSEMBLY. INSTRUCTIONS MAY VARY IN CURB STYLES AND SUPERSEDES INFORMATION SHOWN.**

See the manual shipped with the roof curb for assembly and installation instructions.

## CLEARANCES

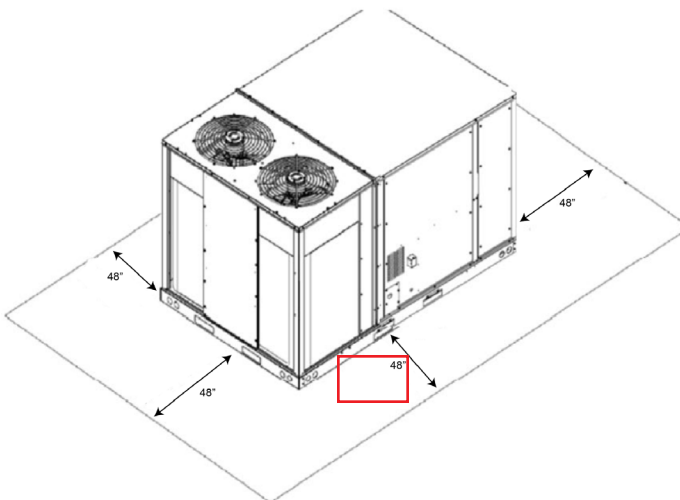

**UNIT CLEARANCES  
FIGURE 1**

*\*In situations that have multiple units, a 48" minimum clearance is required between the condenser coils.*

Clearance in accordance with local installation codes, the requirements of the gas supplier and the manufacturer's installation instructions.

Adequate clearance around the unit should be kept for safety, service, maintenance, and proper unit operation. A clearance of 48" is recommended on all sides of the unit to facilitate possible parts replacement, to allow service access and to insure proper ventilation and condenser airflow. The top of the unit should be completely unobstructed. If units are to be located under an overhang, there should be a minimum of 48" clearance and provisions made to deflect the warm discharge air out from the overhang. The unit should be installed remote from all building exhausts to inhibit ingestion of exhaust air into the unit fresh air intake.

**NOTE: IF THE 48" MINIMUM CLEARANCE IS USED ON THE CONTROL PANEL SIDE OF A DSG UNIT, A FLUE EXTENSION KIT NEEDS BE TO INSTALLED TO PREVENT FLUE GAS RECIRCULATION. SEE TABLE BELOW FOR THE KIT SELECTION.**

| Model size       | Kit part number |
|------------------|-----------------|
| 7.5, 8.5, & 10 T | HEFLUE090120    |
| 12.5 T           | HEFLUE150       |

## FLUE EXTENSION KITS

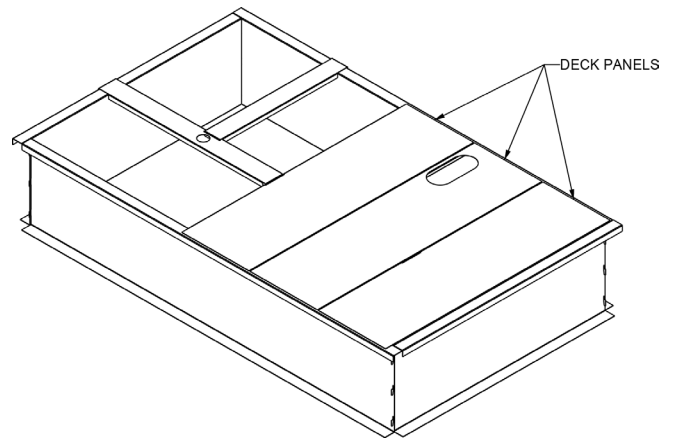

**ROOF CURB INSTALLATION  
FIGURE 2**

## ROOF CURB POST-INSTALLATION CHECKS

After installation, check the top of the curb, duct connection frame and duct flanges to make sure gasket has been applied properly. Gasket should be firmly applied to the top of the curb perimeter, duct flanges and any exposed duct connection frame. If gasket is loose, re-apply using strong weather resistant adhesive.

| Knocked Down Roof Curbs |               |             |
|-------------------------|---------------|-------------|
| UNIT TONNAGE            | DESCRIPTION   | PART NUMBER |
| 7.5 to 12.5             | Curb 14" Tall | 0270L01153  |
|                         | Curb 24" Tall | 0270L01154  |

### PROTRUSION

Inspect curb to ensure that none of the utility services (electric) routed through the curb protrude above the curb.

|  |
|--|
|  <b>CAUTION</b> |
| <b>IF PROTRUSIONS EXIST, DO NOT ATTEMPT TO SET UNIT ON CURB.</b>                                 |

## ROOF TOP DUCT CONNECTIONS

Install all duct connections on the unit before placing the unit on rooftop.

### HORIZONTAL DISCHARGE

Refer to IOD-7082 included in the literature pack for installing horizontal duct covers.

Flexible duct connectors between the unit and ducts are recommended. Insulate and weatherproof all external ductwork and joints as required and in accordance with local codes.

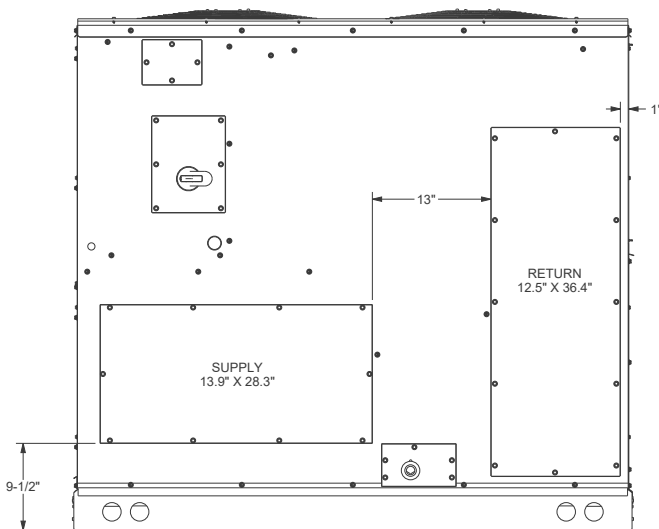

**HORIZONTAL DISCHARGE DUCT CONNECTIONS  
FIGURE 3**

## RIGGING DETAILS

|  |
|--|
|  <b>WARNING</b>   |
| <b>TO PREVENT PROPERTY DAMAGE, THE UNIT SHOULD REMAIN IN AN UPRIGHT POSITION DURING ALL RIGGING AND MOVING OPERATIONS. TO FACILITATE LIFTING AND MOVING WHEN A CRANE IS USED, PLACE THE UNIT IN AN ADEQUATE CABLE SLING.</b> |

|   |
|---|
|  <b>CAUTION</b>  |
| <b>DO NOT LIFT UNITS TWO AT A TIME. PROVISIONS FOR FORKS HAVE BEEN INCLUDED IN THE UNIT BASE FRAME. MINIMUM FORK LENGTH IS 72" TO PREVENT DAMAGE TO THE UNIT.</b> |

**PROVISIONS FOR FORKS HAVE BEEN INCLUDED IN THE UNIT BASE FRAME. NO OTHER FORK LOCATIONS ARE APPROVED.**

|  |
|--|
|  <b>WARNING</b>   |
| <b>TO PREVENT POSSIBLE EQUIPMENT DAMAGE, PROPERTY DAMAGE, PERSONAL INJURY OR DEATH, THE FOLLOWING BULLET POINTS MUST BE OBSERVED WHEN INSTALLING THE UNIT.</b> |

- Unit must be lifted by the four lifting holes located at the base frame corners.
- Lifting cables should be attached to the unit with shackles.
- The distance between the crane hook and the top of the unit must not be less than 60".
- Two spreader bars must span over the unit to prevent damage to the cabinet by the lift cables. Spreader bars must be of sufficient length so that cables do not come in contact with the unit during transport. Remove wood struts mounted beneath unit base frame before setting unit on roof curb. These struts are intended to protect unit base frame from fork lift damage. Removal is accomplished by extracting the sheet metal retainers and pulling the struts through the base of the unit. Refer to rigging label on the unit.
- Your unit may be equipped with a steel shipping brace located underneath the unit (under compressors). If installing on a roof curb, the brace **MUST** be removed. Follow the following instructions for removal.

|  |
|--|
|  <b>CAUTION</b>   |
| <b>WHEN UNIT IS SUSPENDED, BOARDS AND SHIPPING BRACE WILL DROP WHEN SCREWS ARE REMOVED. TO PREVENT PERSONAL INJURY, STAND CLEAR. REMOVE FORK HOLE BRACKETS, BOARDS AND SHIPPING BRACE FROM BOTTOM OF UNIT BEFORE PLACING UNIT ONTO CURB.</b> |

**BEFORE INSTALLING THIS UNIT ON A ROOF CURB:**

1. Remove wooden struts per installation instructions. *These are the struts that are located in the fork holes and are used to protect the unit from damage while lifting with forklifts.*
2. Locate and remove the four (4) screws that attach the shipping brace to the side rails. There will be two (2) screws on each side of the unit. *See following figure.*

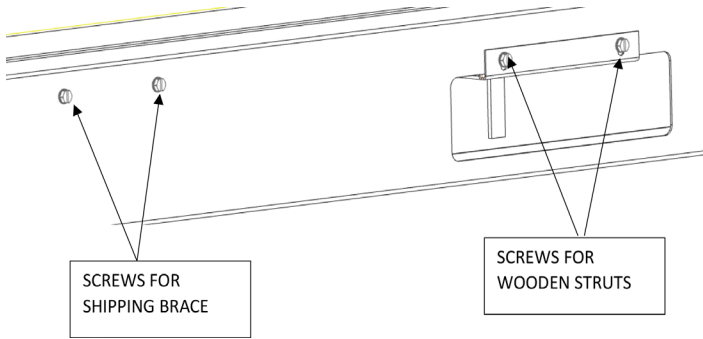

**SHIPPING BRACE SCREW AND WOODEN STRUTS LOCATIONS**  
**FIGURE 4**

3. Lift unit per the “Rigging Details” section of the installation instructions, observing all warnings and cautions. Lift the unit high enough off the ground to reach under and grasp the shipping brace.
4. Rotate the brace by tapping the ends until the brace falls free from the unit.
5. Dispose of the brace appropriately.

**IMPORTANT: IF USING BOTTOM DISCHARGE WITH ROOF CURB, DUCTWORK SHOULD BE ATTACHED TO THE CURB PRIOR TO INSTALLING THE UNIT. DUCTWORK DIMENSIONS ARE SHOWN IN ROOF CURB INSTALLATION INSTRUCTIONS.**

Refer to the Roof Curb Installation Instructions for proper curb installation. Curbing must be installed in compliance with the National Roofing Contractors Association Manual.

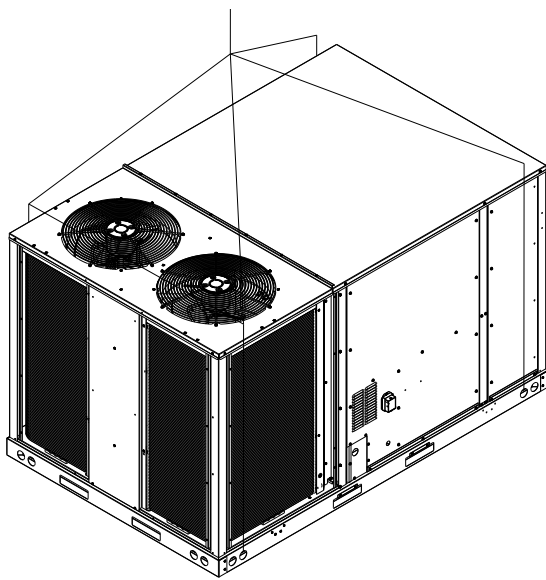

**UNIT RIGGING**  
**FIGURE 5**

To assist in determining rigging requirements, unit weights and center of gravity are shown as follows:

**WEIGHTS AND CENTER OF GRAVITY**

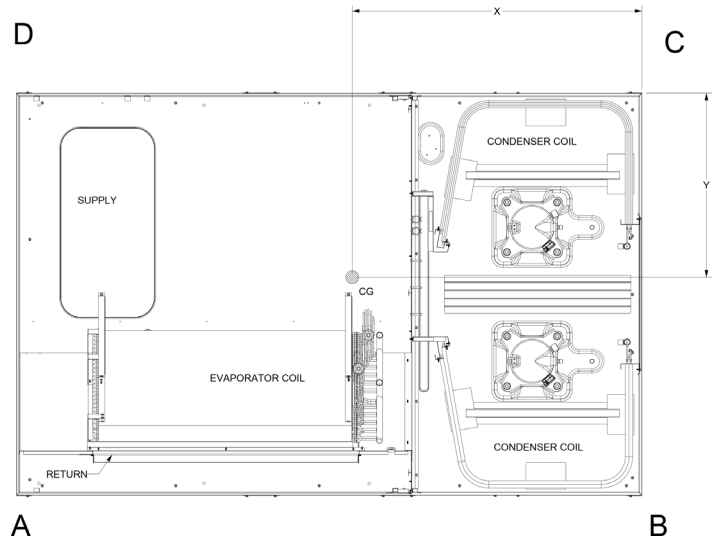

**CORNER AND CENTER OF GRAVITY LOCATIONS**  
**FIGURE 6**

**NOTE: UNIT SHOULD BE LIFTED AT A POINT ABOVE CENTER OF GRAVITY.**

| <b>DSG WEIGHTS (lbs)</b>     |             |             |            |              |
|------------------------------|-------------|-------------|------------|--------------|
| <b>Data</b>                  | <b>7.5T</b> | <b>8.5T</b> | <b>10T</b> | <b>12.5T</b> |
| <b>Corner weight- A</b>      | 266         | 386         | 252        | 254          |
| <b>Corner weight- B</b>      | 249         | 165         | 303        | 329          |
| <b>Corner weight- C</b>      | 297         | 225         | 258        | 297          |
| <b>Corner weight- D</b>      | 294         | 342         | 348        | 364          |
| <b>Unit operating weight</b> | 1106        | 1118        | 1161       | 1244         |
| <b>Unit shipping weight</b>  | 1178        | 1190        | 1233       | 1316         |
| <b>X Center</b>              | 30.4        | 30.4        | 31         | 29.8         |
| <b>Y Center</b>              | 42          | 41.3        | 43.4       | 42.5         |

**THE NUMBERS MAY SLIGHTLY VARY DEPENDING ON INSTALLED OPTIONS.**

**⚠ CAUTION**

**TO PREVENT SEVERE DAMAGE TO THE BOTTOM OF THE UNIT, DO NOT FORK LIFT UNIT AFTER WOOD STRUTS HAVE BEEN REMOVED.**

Bring condenser end of unit into alignment with the curb first. Lower unit carefully onto roof mounting curb. When a rectangular cantilever curb is used, care should be taken to center the unit. Check for proper alignment and orientation of supply and return openings with duct.

## RIGGING REMOVAL



### CAUTION

**TO PREVENT DAMAGE TO THE UNIT, DO NOT ALLOW CRANE HOOKS AND SPREADER BARS TO REST ON THE ROOF OF THE UNIT.**

Remove spreader bars, lifting cables and other rigging equipment.

## ELECTRICAL WIRING



### WARNING

**HIGH VOLTAGE!  
DISCONNECT ALL POWER BEFORE SERVICING OR INSTALLING THIS UNIT. MULTIPLE POWER SOURCES MAY BE PRESENT. FAILURE TO DO SO MAY CAUSE PROPERTY DAMAGE, PERSONAL INJURY OR DEATH.**



### WARNING

**HIGH VOLTAGE!  
TO AVOID PERSONAL INJURY OR DEATH DUE TO ELECTRICAL SHOCK, DO NOT TAMPER WITH FACTORY WIRING. THE INTERNAL POWER AND CONTROL WIRING OF THESE UNITS ARE FACTORY-INSTALLED AND HAVE BEEN THOROUGHLY TESTED PRIOR TO SHIPMENT. CONTACT YOUR LOCAL REPRESENTATIVE IF ASSISTANCE IS REQUIRED.**



### CAUTION

**TO PREVENT DAMAGE TO THE WIRING, PROTECT WIRING FROM SHARP EDGES. FOLLOW NATIONAL ELECTRICAL CODE AND ALL LOCAL CODES AND ORDINANCES. DO NOT ROUTE WIRES THROUGH REMOVABLE ACCESS PANELS.**



### CAUTION

**CONDUIT AND FITTINGS MUST BE WEATHER-TIGHT TO PREVENT WATER ENTRY INTO THE BUILDING.**

For unit protection, use a fuse or HACR circuit breaker that is in excess of the circuit ampacity, but less than or equal to the maximum overcurrent protection device. DO NOT EXCEED THE MAXIMUM OVERCURRENT DEVICE SIZE SHOWN ON UNIT DATA PLATE.

All line voltage connections must be made through weatherproof fittings. All exterior power supply and ground wiring must be in approved weatherproof conduit.

The main power supply wiring to the unit and low voltage wiring to accessory controls must be done in accordance with these instructions, the latest edition of the National Electrical Code (ANSI/NFPA 70), and all local codes and ordinances.

The main power supply shall be three-phase, three wire.

The unit is factory wired for the voltage shown on the unit's data plate.

**NOTE: IF SUPPLY VOLTAGE IS 208V, LEAD ON PRIMARY OF TRANSFORMER(S) MUST BE MOVED FROM THE 230V TO THE 208V TAP. REFER TO WIRING DIAGRAM ON UNIT FOR DETAILS.**

Main power wiring should be sized for the minimum circuit ampacity shown on the unit's database. Size wires in accordance with the ampacity tables in Article 310 of the National Electrical Code. If long wires are required, it may be necessary to increase the wire size to prevent excessive voltage drop. Wires should be sized for a maximum of 3% voltage drop.



### CAUTION

**TO AVOID RISK OF PROPERTY DAMAGE, PERSONAL INJURY OR FIRE, USE ONLY COPPER CONDUCTORS.**



### CAUTION

**TO PREVENT IMPROPER AND DANGEROUS OPERATION DUE TO WIRING ERRORS, LABEL ALL WIRES PRIOR TO DISCONNECTION WHEN SERVICING CONTROLS. VERIFY PROPER OPERATION AFTER SERVICING.**

**NOTE: A WEATHER-TIGHT DISCONNECT SWITCH, PROPERLY SIZED FOR THE UNIT TOTAL LOAD, MUST BE FIELD OR FACTORY INSTALLED. AN EXTERNAL FIELD SUPPLIED DISCONNECT MAY BE MOUNTED ON THE EXTERIOR PANEL.**

Ensure the data plate is not covered by the field-supplied disconnect switch.

- Some disconnect switches are not fused. Protect the power leads at the point of distribution in accordance with the unit data plate.

- The unit must be electrically grounded in accordance with local codes or, in the absence of local codes, with the latest edition of the National Electrical Code ANSI/NFPA 70, and/or the Canadian Electrical Code, CSA C22.1, Part 1. A ground lug is provided for this purpose. Do not use the ground lug for connecting a neutral conductor.
- Connect power wiring to the electrical power block located within the main control box.

WARNING

**FAILURE OF UNIT DUE TO OPERATION ON IMPROPER LINE VOLTAGE OR WITH EXCESSIVE PHASE UNBALANCE CONSTITUTES PRODUCT ABUSE AND WILL VOID YOUR WARRANTY AND MAY CAUSE SEVERE DAMAGE TO THE UNIT ELECTRICAL COMPONENTS.**

**AREAS WITHOUT CONVENIENCE OUTLET**

It is recommended that an independent 115V power source be brought to the vicinity of the roof top unit for portable lights and tools used by the service mechanic.

**NOTE: REFER TO LOCAL CODES FOR REQUIREMENTS. THESE OUTLETS CAN ALSO BE FACTORY INSTALLED.**

**UNITS INSTALLED ON ROOF TOPS**

Main power and low voltage wiring may enter the unit through the condenser end of unit or through the roof curb. Install conduit connectors at the desired entrance locations. External connectors must be weatherproof. All holes in the unit base must be sealed (including those around conduit nuts) to prevent water leakage into building. All required conduit and fittings are to be field supplied.

Supply voltage to roof top unit must not vary by more than 10% of the value indicated on the unit data plate. Phase voltage unbalance must not exceed 2%. Contact your local power company for correction of improper voltage or phase unbalance.

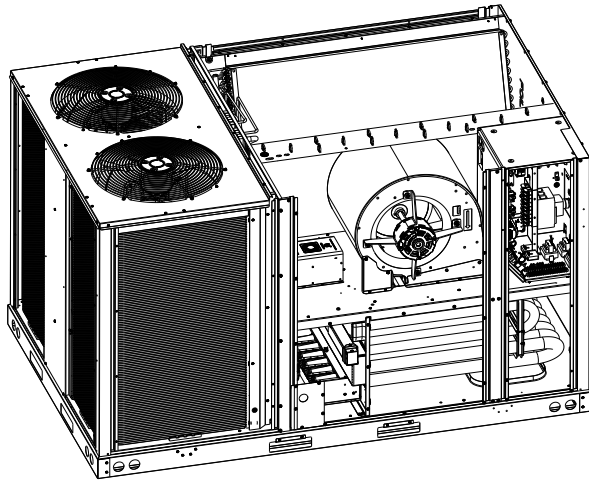

**FIGURE 7A**

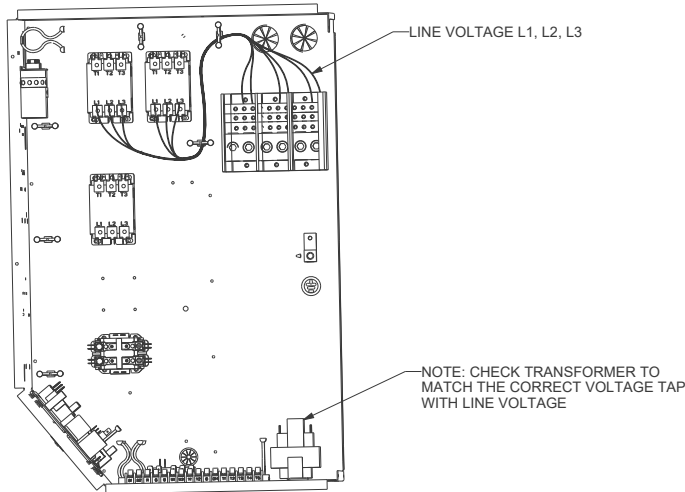

**CONTROL BOX  
FIGURE 7B**

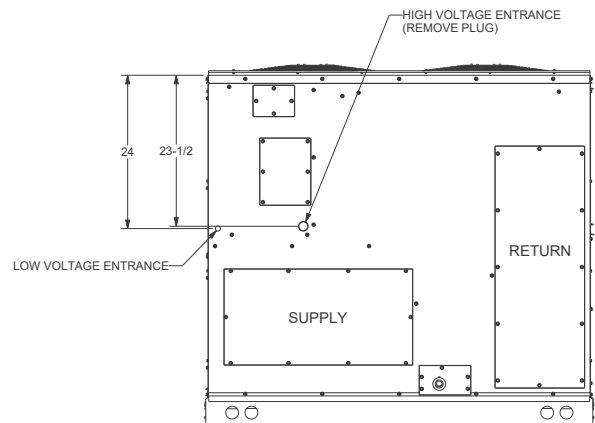

**FIGURE 8A**

**NOTE: DEPENDING ON THE OPTIONS INSTALLED, THE LOCATION OF THE COMPONENTS MAY VARY IN SOME MODELS.**

## GAS SUPPLY PIPING

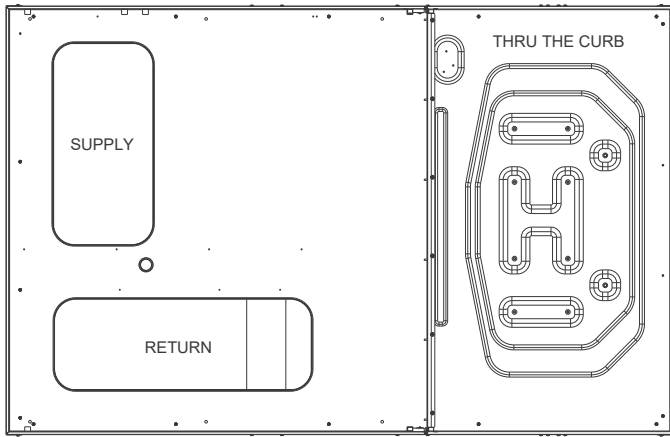

**FIGURE 8B**  
**ELECTRICAL ENTRANCE AND THRU CURB**  
**(BOTTOM VIEW OF UNIT)**

|   |
|---|
| "Through the Base Pan Kit" Part Numbers |
| TTBCKHE02                               |
| TTBCKHE02FI (Factory Kit)               |

### LOW VOLTAGE CONTROL WIRING

1. A 24V thermostat must be installed for unit operation unless the DDC controls option has been installed.
2. Locate thermostat or remote sensor in the conditioned space where it will sense average temperature. Do not locate the device where it may be directly exposed to supply air, sunlight or other sources of heat. Follow installation instructions packaged with the thermostat.
3. Use #18 AWG wire for 24V control wiring runs not exceeding 75 feet. Use #16 AWG wire for 24V control wiring runs not exceeding 125 feet. Use #14 AWG wire for 24V control wiring runs not exceeding 200 feet. Low voltage wiring may be National Electrical Code (NEC) Class 2 where permitted by local codes.
4. Route thermostat wires from sub-base terminals to the unit. Control wiring should enter through the condenser panel opening or through curb indicated in "Electrical Entrance" figure. Connect thermostat and any accessory wiring to low voltage terminal block TB1 in the main control box.

**NOTE: FIELD-SUPPLIED CONDUIT MAY NEED TO BE INSTALLED DEPENDING ON UNIT/CURB CONFIGURATION. USE #18 AWG SOLID CONDUCTOR WIRE WHENEVER CONNECTING THERMOSTAT WIRES TO TERMINALS ON SUB-BASE. DO NOT USE LARGER THAN #18 AWG WIRE. A TRANSITION TO #18 AWG WIRE MAY BE REQUIRED BEFORE ENTERING THERMOSTAT SUB-BASE.**

**NOTE: REFER TO UNIT WIRING DIAGRAMS FOR THERMOSTAT OR REMOTE SENSOR CONNECTIONS.**



### WARNING

**TO PREVENT PERSONAL INJURY OR DEATH DUE TO IMPROPER INSTALLATION, ADJUSTMENT, ALTERATION, SERVICE OR MAINTENANCE, REFER TO THIS MANUAL. FOR ADDITIONAL ASSISTANCE OR INFORMATION, CONSULT A QUALIFIED INSTALLER, SERVICER AGENCY OR THE GAS SUPPLIER.**

**IMPORTANT NOTE: THIS UNIT IS FACTORY SET TO OPERATE ON NATURAL GAS AT THE ALTITUDES SHOWN ON THE RATING PLATE.**



### WARNING

**TO AVOID PROPERTY DAMAGE, PERSONAL INJURY OR DEATH WHEN EITHER USING PROPANE GAS ALONE OR AT HIGHER ALTITUDES, OBTAIN AND INSTALL THE PROPER CONVERSION KIT(S). FAILURE TO DO SO CAN RESULT IN UNSATISFACTORY OPERATION AND/OR EQUIPMENT DAMAGE. HIGH ALTITUDE KITS ARE FOR U.S. INSTALLATIONS ONLY AND ARE NOT APPROVED FOR USE IN CANADA.**

The rating plate is stamped with the model number, type of gas and gas input rating. Make sure the unit is equipped to operate on the type of gas available. Conversion to propane (LP) gas is permitted with the use of the factory authorized conversion kit (see the unit Technical Manual for the appropriate kit). For High Altitude derates, refer to the latest edition of the National Fuel Gas Code NFPA 54/ANSI Z223.1 or National Standard of Canada, Natural Gas and Propane Installation Code, CSA B149.1.

Installation of this furnace at altitudes above 2000 ft (610 m) shall be made in accordance with the Listed High Altitude Conversion Kit available with this furnace."

| INLET GAS PRESSURE |                                  |
|--------------------|----------------------------------|
| <b>NATURAL</b>     | Min. 5.0" W.C., Max. 10.0" W.C.  |
| <b>PROPANE</b>     | Min. 11.0" W.C., Max. 14.0" W.C. |

**INLET GAS PRESSURE MUST NOT EXCEED MAXIMUM VALUE SHOWN IN TABLE ABOVE.**

The minimum supply pressure should not vary from that shown in the table above because this could prevent the unit from having dependable ignition. In addition, gas input to the burners must not exceed the rated input shown on the rating plate. Overfiring of the unit could result in premature heat exchanger failure.

**PIPING**

**IMPORTANT NOTE: To AVOID POSSIBLE UNSATISFACTORY OPERATION OR EQUIPMENT DAMAGE DUE TO UNDER FIRING OF EQUIPMENT, DO NOT UNDERSIZE THE NATURAL/PROPANE GAS PIPING FROM THE METER/TANK TO THE UNIT. WHEN SIZING A TRUNK LINE, INCLUDE ALL APPLIANCES ON THAT LINE THAT COULD BE OPERATED SIMULTANEOUSLY.**

The gas line installation must comply with local codes, or in the absence of local codes, with the latest edition of the National Fuel Gas Code NFPA 54 / ANSI Z223.1.

**NATURAL GAS CONNECTION**

| Natural Gas Capacity of Pipe<br>in Cubic Feet of Gas Per Hour (CFH) |                                  |     |     |       |       |
|---|----------------------------------|-----|-----|-------|-------|
| Length of<br>Pipe in Feet   | Nominal Black Pipe Size (inches) |     |     |       |       |
|   | 1/2                              | 3/4 | 1   | 1 1/4 | 1 1/2 |
| 10  | 132                              | 278 | 520 | 1050  | 1600  |
| 20  | 92                               | 190 | 350 | 730   | 1100  |
| 30  | 73                               | 152 | 285 | 590   | 980   |
| 40  | 63                               | 130 | 245 | 500   | 760   |
| 50  | 56                               | 115 | 215 | 440   | 670   |
| 60  | 50                               | 105 | 195 | 400   | 610   |
| 70  | 46                               | 96  | 180 | 370   | 560   |
| 80  | 43                               | 90  | 170 | 350   | 530   |
| 90  | 40                               | 84  | 160 | 320   | 490   |
| 100   | 38                               | 79  | 150 | 305   | 460   |

Pressure= .50 PSIG or less and Pressure Drop of 0.3" W.C.  
(Based on 0.60 Specific Gravity Gas)

$$CFH = \frac{BTUH \text{ Furnace Input}}{\text{Heating Value of Gas (BTU/Cubic Foot)}}$$

Refer to the Proper Piping Practice drawing for the general layout at the unit. The following rules apply:

1. Use black iron pipe and fittings for the supply piping. The use of a flex connector and/or copper piping is permitted as long as it is in agreement with local codes.
2. Use pipe joint compound on male threads only. Pipe joint compound must be resistant to the action of the fuel used.
3. Use ground joint unions.
4. Install a drip leg to trap dirt and moisture before it can enter the gas valve. The drip leg must be a minimum of three inches long.
5. Use two pipe wrenches when making connection to the gas valve to keep it from turning.
6. Install a manual shut-off valve in a convenient location (within six feet of unit) between the meter and the unit.
7. Tighten all joints securely.
8. The unit must be connected to the building piping by one of the following methods:
  - Rigid metallic pipe and fittings
  - Semirigid metallic tubing and metallic fittings (Aluminum alloy tubing must not be used in exterior locations).

- Listed gas appliance connectors used in accordance with the terms of their listing that are completely in the same room as the equipment. Always use a new listed connector.
- In the prior two methods above the connector or tubing must be protected from physical and thermal damage. Aluminum alloy tubing and connectors must be coated to protect against external corrosion when in contact with masonry, plaster or insulation or are subject to repeated wettings by liquids (water - not rain water, detergents or sewage).

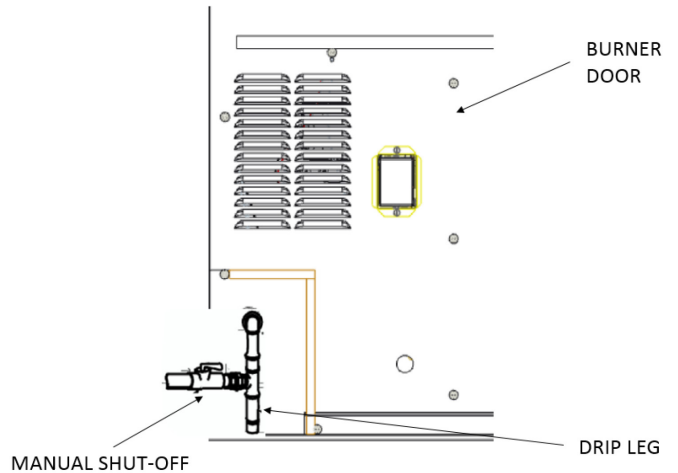

**PROPER PIPING PRACTICE  
FIGURE 9**

**NOTE: THE UNIT GAS SUPPLY ENTRANCE IS FACTORY SEALED WITH PLUGS. KEEP PLUGS IN PLACE UNTIL GAS SUPPLY IS READY TO BE INSTALLED. ONCE READY, REPLACE THE PLUGS WITH THE SUPPLIED GROMMETS AND INSTALL GAS SUPPLY LINE.**

## GAS PIPING CHECKS



### CAUTION

TO PREVENT PROPERTY DAMAGE OR PERSONAL INJURY DUE TO FIRE, THE FOLLOWING INSTRUCTIONS MUST BE PERFORMED REGARDING GAS CONNECTIONS AND PRESSURE TESTING:

- THE UNIT AND ITS GAS CONNECTIONS MUST BE LEAK TESTED BEFORE PLACING IN OPERATION. BECAUSE OF THE DANGER OF EXPLOSION OR FIRE, NEVER USE A MATCH OR OPEN FLAME TO TEST FOR LEAKS. NEVER EXCEED SPECIFIED PRESSURES FOR TESTING. HIGHER PRESSURE MAY DAMAGE GAS VALVE AND CAUSE OVERFIRING WHICH MAY RESULT IN PREMATURE HEAT EXCHANGE FAILURE.
- THIS UNIT AND ITS SHUT-OFF VALVE MUST BE DISCONNECTED FROM THE GAS SUPPLY DURING ANY PRESSURE TESTING OF THAT SYSTEM AT TEST PRESSURES IN EXCESS OF ½ PSIG (3.48 kPa).
- THIS UNIT MUST BE ISOLATED FROM THE GAS SUPPLY SYSTEM BY CLOSING ITS MANUAL SHUT-OFF VALVE DURING ANY PRESSURE TESTING OF THE GAS SUPPLY PIPING SYSTEM AT TEST PRESSURES EQUAL TO OR LESS THAN ½ PSIG (3.48 kPa).



### WARNING

TO AVOID PROPERTY DAMAGE OR PERSONAL INJURY, BE SURE THERE IS **NO OPEN FLAME** IN THE VICINITY DURING AIR BLEEDING.

There will be air in the gas supply line after testing for leaks on a new installation. Therefore, the air must be bled from the line by loosening the ground joint union until pure gas is expelled. Tighten union and wait for five minutes until all gas has been dissipated in the air. Be certain there is no open flame in the vicinity during air bleeding procedure. The unit is placed in operation by closing the main electrical disconnect switch for the unit.

## PROPANE GAS INSTALLATIONS



### WARNING

TO AVOID PROPERTY DAMAGE, PERSONAL INJURY OR DEATH DUE TO FIRE OR EXPLOSION CAUSED BY A PROPANE GAS LEAK, INSTALL A GAS DETECTING WARNING DEVICE. SINCE RUST CAN REDUCE THE LEVEL OF ODORANT IN PROPANE GAS, A GAS DETECTING WARNING DEVICE IS THE ONLY RELIABLE WAY TO DETECT A PROPANE GAS LEAK. CONTACT A LOCAL PROPANE GAS SUPPLIER ABOUT INSTALLING A GAS DETECTING WARNING DEVICE.

**IMPORTANT NOTE: PROPANE GAS CONVERSION KITS MUST BE INSTALLED TO CONVERT UNITS TO PROPANE GAS. NOX SCREENS MUST BE REMOVED BEFORE CONVERTING TO LP. REMOVE BURNER ASSEMBLY AND PULL NOX SCREENS FROM EACH BURNER TUBE. WHEN ALL THE SCREENS ARE OUT, REASSEMBLE THE BURNER ASSEMBLY WITHOUT THE SCREENS.**

All propane gas equipment must conform to the safety standards of NFPA 58 - Liquefied Petroleum Gas Code.

For satisfactory operation, propane gas pressure must be within 9.7 - 10.3 inches w.c. for high fire at the manifold with all gas appliances in operation. Maintaining proper gas pressure depends on three main factors:

1. Vaporization rate, which depends on (a) temperature of the liquid, and (b) wetted surface area of the container or containers.
2. Proper pressure regulation.
3. Pressure drop in lines between regulators, and between second stage regulator and the appliance. Pipe size required will depend on length of pipe run and total load of all appliances.

### TANKS AND PIPING

Complete information regarding tank sizing for vaporization, recommended regulator settings and pipe sizing is available from most regulator manufacturers and propane gas suppliers.

Since propane gas will quickly dissolve white lead or most standard commercial compounds, special pipe dope must be used. Shellac base compounds resistant to the actions of liquefied petroleum gases such as Gasolac®, Stalactic®, Clyde's® or John Crane® are satisfactory.

See the following figure for typical propane gas piping.

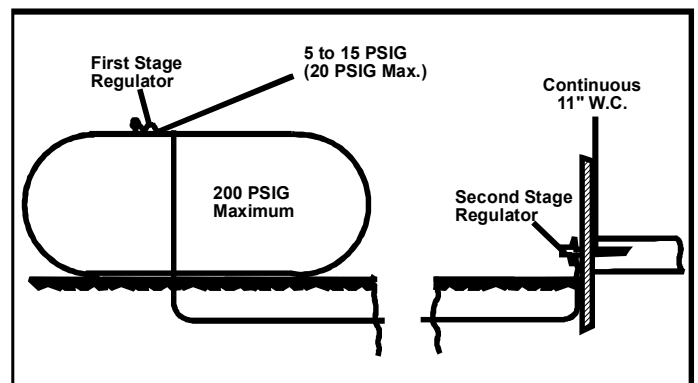

TYPICAL PROPANE GAS PIPING  
FIGURE 10

### ROOF TOP LOCATION AND INSTALLATION

The gas supply piping location and installation for roof top units must be in accordance with local codes or, in the absence of local codes, with ordinances of the latest edition of the National Fuel Gas Code ANSI Z223.1/NFPA 54.



A manual gas shut off valve must be field installed external to the roof top unit. In addition, a drip leg must be installed near the inlet connection. A ground joint union connection is required between the external shut off valve and the unit connection to the gas valve to permit removal of the burner assembly for servicing.

1. Route gas piping to unit so that it does not interfere with the removal of access panels. Support and align piping to prevent strains or misalignment of the manifold assembly.
2. All units are furnished with standard female 1/2" NPT pipe connections. The size of the gas supply piping to the unit must be based on length of run, number of units on the system, gas characteristics, BTU requirement and available supply pressure. All piping must be done in accordance with local codes or, in the absence of local codes, with the latest edition of the National Fuel Gas Code ANSI Z223.1/NFPA 54.

**NOTE: THE GAS CONNECTION SIZE AT THE UNIT DOES NOT ESTABLISH THE SIZE OF THE SUPPLY LINE.**

3. These units are designed for either natural or propane (LP) gas and are specifically constructed at the factory for only one of these fuels. The fuels are NOT interchangeable. However, the furnace can be converted in the field from natural gas to LP gas with the appropriate factory kit (see unit Technical Manual for the appropriate kit). Only a qualified contractor, experienced with natural and propane gas systems, should attempt conversion. Kit instructions must be followed closely to assure safe and reliable unit operation.
4. With all units on a common line operating under full fire, natural gas main supply pressure should be adjusted to approximately 7.0" w.c., measured at the unit gas valve. If the gas pressure at the unit is greater than 10.5" w.c., the contractor must furnish and install an external type positive shut off service pressure regulator. The unit will not function satisfactorily if supply gas pressure is less than 5.5" w.c. or greater than 10.5" w.c..

**NOTE: A MINIMUM HORIZONTAL DISTANCE OF 48" BETWEEN THE REGULATOR AND THE FURNACE FLUE DISCHARGE IS REQUIRED.**

5. With all units on a common line operating under full LP gas main supply pressure should be at least 11.0" w.c. and must be no greater than 14.0" w.c., measured at the unit gas valve. Unit will not function satisfactorily if supply gas pressure is less than 11.0" w.c. or greater than 14.0" w.c..
6. All pipe connections should be sealed with a pipe thread compound, which is resistant to the fuel used with the furnace. A soapy water solution should be used to check all joints for leaks. A 1/8" NPT plugged tap is located on the entering side of the gas valve for test gauge connection to measure supply (main) gas pressure. Another 1/8" tap is provided on the side of the manifold for checking manifold pressure.



## WARNING

**THIS UNIT AND ITS INDIVIDUAL SHUTOFF VALVE MUST BE DISCONNECTED FROM THE GAS SUPPLY SYSTEM DURING ANY PRESSURE TESTING OF THAT SYSTEM AT TEST PRESSURES IN EXCESS OF ½ PSIG (13.8" w.c.).**



## CAUTION

**THIS UNIT MUST BE ISOLATED FROM THE GAS SUPPLY PIPING SYSTEM BY CLOSING ITS INDIVIDUAL MANUAL SHUTOFF VALVE DURING ANY PRESSURE TESTING EQUAL TO OR LESS THAN ½ PSIG.**

7. There must be no obstruction to prevent the flow of combustion and ventilating air. A vent stack is not required and must never be used. The power venter will supply an adequate amount of combustion air as long as the air passageways are kept free of any obstructions and the recommended external unit clearances are maintained.

## CIRCULATING AIR AND FILTERS

### DUCTWORK

The supply duct from the unit through a wall may be installed without clearance. However, minimum unit clearances must be maintained (see "Clearances" section). The supply duct should be provided with an access panel large enough to inspect the air chamber downstream of the heat exchanger. False ceilings or drop ceilings may be used as a return air plenum. A cover should be tightly attached to prevent air leaks.

**NOTE: ADEQUATE RETURN GRILLS HAVE TO BE SUPPLIED FOR EACH ROOM FOR PROPER RETURN FOR THAT SPACE.**

Ductwork dimensions are shown in the roof curb installation manual.

If desired, supply and return duct connections to the unit may be made with flexible connections to reduce possible unit operating sound transmission.

## VENTING

**NOTE: VENTING IS SELF-CONTAINED.**

The inductor motor on DSG units is a dual voltage motor. It is factory wired for 230 volts. If field supply power is 208V, the installer must swap the connections of the black and red leads (located in the blower compartment) to ensure correct inductor motor operation.

## CONDENSATE DRAIN CONNECTION

### CONDENSATE DRAIN CONNECTION

A 3/4" female NPT drain connection is supplied on the end of the unit and bottom of the drain pan for condensate piping. An external trap must be installed for proper condensate drainage. Hand tighten drain fitting to the drain connection.

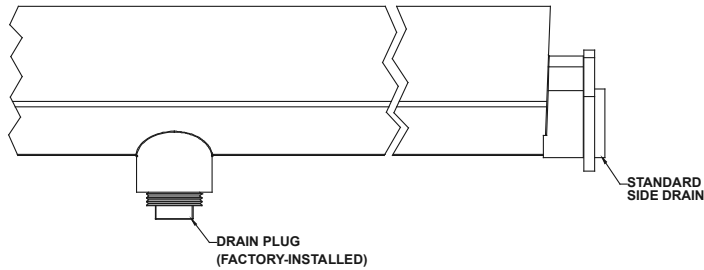

**DRAIN PAN (SIDE VIEW)**  
**FIGURE 11**

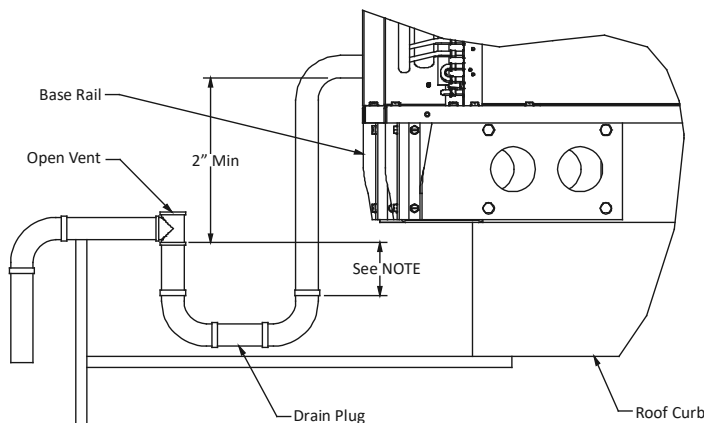

**NOTE:** Trap should be deep enough to offset maximum unit static difference. A minimum 4" trap is recommended.

**DRAIN CONNECTION**  
**FIGURE 12**

Install condensate drain trap as shown. Use 3/4" drain line and fittings or larger. Do not operate without trap.

### HORIZONTAL DRAIN

Drainage of condensate directly onto the roof may be acceptable; refer to local code. It is recommended that a small drip pad of either stone, mortar, wood or metal be provided to prevent any possible damage to the roof.

### VERTICAL DRAIN

To use the bottom drain connection, remove the drain plug from the bottom connection and install it in the horizontal connection.

**NOTE: ALL THREADED CONNECTIONS USE PIPE SEALER.**

### CLEANING

Due to the fact that the drain pans in any air conditioning unit will have some moisture in them, algae and fungus will grow due to airborne bacteria and spores. Periodic cleaning is necessary to prevent the build-up from plugging the drain.

To remove the drain pan for cleaning, remove the drain pan cover first (located in horizontal drain pans) then the drain pan could be slid out.

## STARTUP, ADJUSTMENTS, AND CHECKS



### WARNING

#### HIGH VOLTAGE!

**TO AVOID PERSONAL INJURY OR DEATH DUE TO ELECTRICAL SHOCK, BOND THE FRAME OF THIS UNIT TO THE BUILDING ELECTRICAL GROUND BY USE OF THE GROUNDING TERMINAL PROVIDED OR OTHER ACCEPTABLE MEANS. DISCONNECT ALL POWER BEFORE SERVICING OR INSTALLING THIS UNIT.**



### PRE-STARTUP INSTRUCTIONS - GENERAL



### CAUTION

**TO PREVENT PROPERTY DAMAGE OR PERSONAL INJURY, DO NOT START THE UNIT UNTIL ALL NECESSARY PRE-CHECKS AND TESTS HAVE BEEN PERFORMED.**

Prior to the beginning of Startup, Adjustments, and Checks procedures, the following steps should be completed in the building.



### WARNING

#### MOVING MACHINERY HAZARD!

**TO PREVENT POSSIBLE PERSONAL INJURY OR DEATH, DISCONNECT POWER TO THE UNIT AND PADLOCK IN THE "OFF" POSITION BEFORE SERVICING FANS.**

This unit is equipped with an electronic ignition device to automatically light the main burners. It also has a power vent blower to exhaust combustion products.

On new installations, or if a major component has been replaced, the operation of the unit must be checked.

Check unit operation as outlined in the following instructions. If any sparking, odors, or unusual sounds are encountered, shut off electrical power and recheck for wiring errors, or obstructions in or near the blower motors.  
**Duct covers must be removed for horizontal installs.**

The Startup, Adjustments, and Checks procedure provides a step-by-step sequence which, if followed, will assure the proper startup of the equipment in the minimum amount of time. Air balancing of duct system is not considered part of this procedure. However, it is an important phase of any air conditioning system startup and should be performed upon completion of the Startup, Adjustments, and Checks procedure. The Startup, Adjustments, and Checks procedure at outside ambients below 55°F should be limited to a readiness check of the refrigeration system with the required final check and calibration left to be completed when the outside ambient rises above 55°F.

**TEMPORARY HEATING OR COOLING**

If the unit is to be used for temporary heating or cooling, a "Startup, Adjustments, and Checks" must first be performed in accordance with this manual. Damage or repairs due to failure to comply with these requirements are not covered under the warranty. **After** the machines are used for temporary heating or cooling, inspect the coils, fans, and motors for unacceptable levels of construction dust and dirt and install new filters.

**CONTRACTOR RESPONSIBILITY**

The installing contractor must be certain that:

- All supply and return air ductwork is in place, properly sealed, and corresponds with installation instructions.
- All thermostats are mounted and wired in accordance with installation instructions.
- All electric power, all gas, hot water or steam line connections, and the condensate drain installation have been made to each unit on the job. These main supply lines must be functional and capable of operating all units simultaneously.
- Requirements are met for venting and combustion air.
- Air filters are in place.
- Input rate and temperature rise are adjusted per rating plate.

**ROOF CURB INSTALLATION CHECK**

Inspect the roof curb for correct installation. The unit and curb assembly should be level. Inspect the flashing of the roof mounting curb to the roof, especially at the corners, for good workmanship. Also check for leaks around gaskets. Note any deficiencies in a separate report and forward to the contractor.

**OBSTRUCTIONS, FAN CLEARANCE AND WIRING**

Remove any extraneous construction and shipping materials that may be found during this procedure. Rotate all fans manually to check for proper clearances and that they rotate freely. Check for bolts and screws that may have jarred loose during shipment to the job site. Re-tighten if necessary. Re-tighten all electrical connections.

**FIELD DUCT CONNECTIONS**

Verify that all duct connections are tight and that there is no air bypass between supply and return.

**FILTER SECTION CHECK**

Remove filter section access panels and check that filters are properly installed. Note airflow arrows on filter frames.

**PRE-STARTUP PRECAUTIONS**

**TRANSFORMER AND INDUCED DRAFT MOTOR**

**NOTE: ON THE 208/230 VOLT UNITS ONLY.**

Ensure the transformer and induced draft motor are set on the appropriate voltage taps. Both the transformer tap and induced draft motor are set on 230v from the factory. To change the induced draft motor voltage, remove the black induced draft motor wire from the unused terminal on the ignition control board and swap it with the red wire coming from the induced draft motor.

It is important to your safety that the unit has been properly grounded during installation. Check ground lug connection in main control box for tightness prior to closing circuit breaker or disconnect switch. Verify that supply voltage on line side of disconnect agrees with voltage on unit identification plate and is within the utilization voltage range as indicated in Appendix B Electrical Data.

**System Voltage** - That nominal voltage value assigned to a circuit or system for the purpose of designating its voltage class.

**Nameplate Voltage** - That voltage assigned to a piece of equipment for the purpose of designating its voltage class and for the purpose of defining the minimum and maximum voltage at which the equipment will operate.

**Utilization Voltage** - The voltage of the line terminals of the equipment at which the equipment must give fully satisfactory performance. Once it is established that supply voltage will be maintained within the utilization range under all system conditions, check and calculate if an unbalanced condition exists between phases. Calculate percent voltage unbalance as follows.

**THREE PHASE MODELS ONLY**

$$3) \text{ PERCENT VOLTAGE UNBALANCE} = 100 \times \frac{2) \text{ MAXIMUM VOLTAGE DEVIATIONS FROM AVERAGE VOLTAGE}}{1) \text{ AVERAGE VOLTAGE}}$$

HOW TO USE THE FORMULA:

EXAMPLE: Line to Neutral Voltage of 220, 216, and 213

1) Average Voltage = 220+216+213=649 / 3 = 216

2) Maximum Voltage Deviations from Average Voltage = 220 - 216 = 4

$$3) \text{ Percent Voltage Unbalance} = 100 \times \frac{4}{216} = \frac{400}{216} = 1.8\%$$

Percent voltage unbalance MUST NOT exceed 2%.

**CONTROL VOLTAGE CHECK**

Close the disconnect switch to energize control transformer. Check primary and secondary (24V) of control transformer.

### DSG Model Wiring

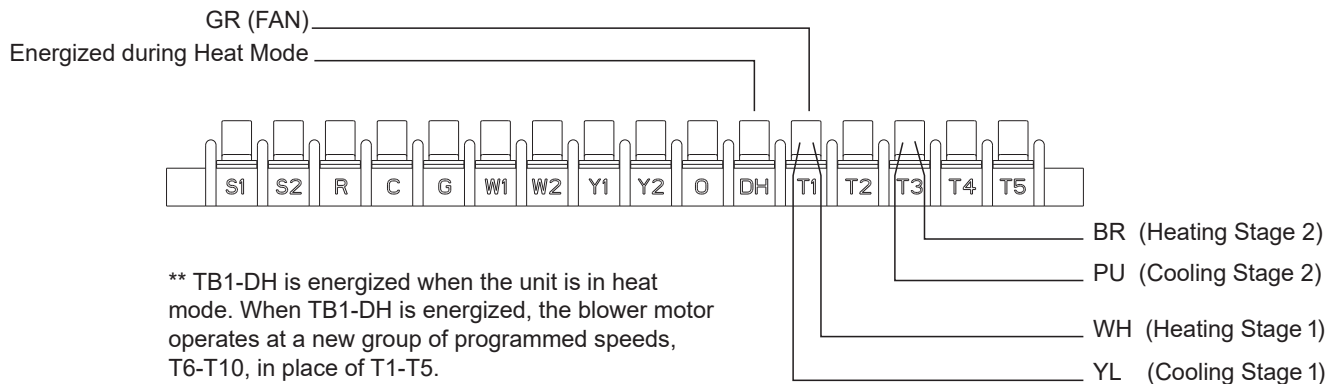

- Move YELLOW (YL) wire from TB1-T1 to T2 to change blower speed during cooling stage 1 operation. (Do not move wires YL and PU to the same taps)
- Move WHITE (WH) wire from TB1-T6 to T7 to change blower speed during heating stage 1 operation. (Do not move wires WH and BR to the same taps)
- Move PURPLE (PU) wire from TB1-T3 to T4 or T5 to change blower speed during cooling stage 2 operation. (Do not move wires YL and PU to the same taps)
- Move BROWN (BR) wire from TB1-T8 to T9 or T10 to change blower speed during heating stage 2 operation. (Do not move wires WH and BR to the same taps)

### DSG OPERATION and WIRE RANGE CHART

| DSG OPERATION   |   |    |    |    |    |    | WIRE RANGE |    |     |    |    |     |    |    |     |     |
|-----------------|---|----|----|----|----|----|------------|----|-----|----|----|-----|----|----|-----|-----|
| AC              | G | Y1 | Y2 | W1 | W2 | DH | T1         | T2 | T3  | T4 | T5 | T6  | T7 | T8 | T9  | T10 |
| Fan Only        | X |    |    |    |    |    | GR         |    |     |    |    |     |    |    |     |     |
| Cooling Mode LO | X | X  |    |    |    |    | ● →        |    |     |    |    |     |    |    |     |     |
| Cooling Mode HI | X | X  | X  |    |    |    |            |    | ● → |    |    |     |    |    |     |     |
| Heating Mode Lo | X |    |    | X  |    |    |            |    |     |    |    | ● → |    |    |     |     |
| Heating Mode HI | X |    |    | X  | X  |    |            |    |     |    |    |     |    |    | ● → |     |

X= 24V Signal

● → = Range of AVAILABLE TAPS

For wire color information and placement, view DSG Model Wiring

### Electrical Input Check

Make preliminary check of evaporator fan ampere draw and verify that motor nameplate amps are not exceeded. A final check of amp draw should be made upon completion of air balancing of the duct system (see Appendix B).\

## AIR FLOW ADJUSTMENTS

When the final adjustments are complete, the current draw of the motor should be checked and compared to the full load current rating of the motor. The amperage must not exceed the service factor stamped on the motor nameplate. The total airflow must not be less than that required for operation of the furnace.

If an economizer is installed, check the unit operating balance with the economizer at full outside air and at minimum outside air.

**NOTE: NEVER RUN HIGH STAGE CFM BELOW 300 CFM PER TON EVAPORATOR FREEZING OR POOR UNIT PERFORMANCE IS POSSIBLE.**

### EEM - STANDARD STATIC DRIVE MOTOR

Adjust the CFM for the unit by changing the position of the low voltage leads on the terminal block TB1. Refer to Appendix A for blower performance at each speed tap. The table below shows RECOMMENDED SPEED TAPS for heating and cooling. Refer to Appendix D for maximum and minimum allowed airflow for heating and cooling.

### HOW TO SET FAN SPEED

#### SET EVAPORATOR FAN RPM

Actual RPM's must be set and verified with a tachometer or strobe light. Refer to Appendix A for basic unit fan RPM. Refer also to "Airflow" section of this manual. With disconnect switch open, disconnect thermostat wires from terminals Y and W. This will prevent heating and mechanical cooling from coming on. Place a jumper wire across terminals R and G at TB1 terminal block. Close disconnect switch; evaporator fan motor will operate so RPM can be checked.

### ELECTRICAL INPUT CHECK

Make preliminary check of evaporator fan ampere draw and verify that motor nameplate amps are not exceeded. A final check of amp draw should be made upon completion of air balancing of the duct system (see Appendix B).

## GAS SYSTEM CHECK

### GAS SUPPLY PRESSURES & REGULATOR ADJUSTMENTS



**WARNING**

**SHOULD OVERHEATING OCCUR OR THE GAS SUPPLY FAIL TO SHUT OFF, TURN OFF THE MANUAL GAS SHUTOFF VALVE EXTERNAL TO THE UNIT BEFORE TURNING OFF THE ELECTRICAL SUPPLY.**



**WARNING**

**TO AVOID PROPERTY DAMAGE, PERSONAL INJURY OR DEATH, DO NOT FIRE GAS UNIT WITH FLUE BOX COVER REMOVED.**

**NOTE: EXCEPT DURING BRIEF PERIODS WHEN GAS PRESSURES ARE BEING MEASURED BY QUALIFIED SERVICE PERSONNEL, THE FURNACE ACCESS PANEL MUST ALWAYS BE SECURED IN PLACE WHEN THE FURNACE IS IN OPERATION. AN INSPECTION PORT IN THE ACCESS PANEL IS PROVIDED TO MONITOR THE FLAME.**

The first step in checking out the gas-fired furnace is to test the gas supply piping to the unit for tightness and purge the system of air using methods outlined in the latest edition of the National Fuel Gas Code ANSI Z223.1 / NFPA 54. Verify that the disconnect switch is in the "OFF" position. A soapy water solution should be used to check for gas leaks. Since the unit is subject to considerable jarring during shipment, it is extremely important that all gas connections and joints be tested for tightness. Gas piping downstream from the unit inlet should be checked for leaks during the subsequent sequence check.

The supply gas pressure should be adjusted to 7.0" w.c. on natural gas and 11.0" on LP gas with the gas burners operating. If there is more than one unit on a common gas line, the pressures should be checked with all units under full fire. A supply pressure tap is provided on the upstream side of the gas valve. A manifold pressure tap is provided on the manifold. The normal manifold pressure for full input is 3.5" w.c. on natural gas and 10.0" w.c. for propane gas. Minimum gas supply pressure is 5.5" w.c. for natural gas and 11.0" for propane gas. In order to obtain rating, gas supply pressure must be 11.0" w.c. for propane gas. The pressure regulator on LP gas models is adjusted for 10.0" w.c. manifold pressure and is intended to prevent over-firing only. Do not attempt adjustment of the built-in pressure regulator unless the supply pressure is at least 7.0" w.c. on natural gas or 14.0" w.c. on propane gas. Check the location of the ignition electrode and the flame sensor for correct gap setting.

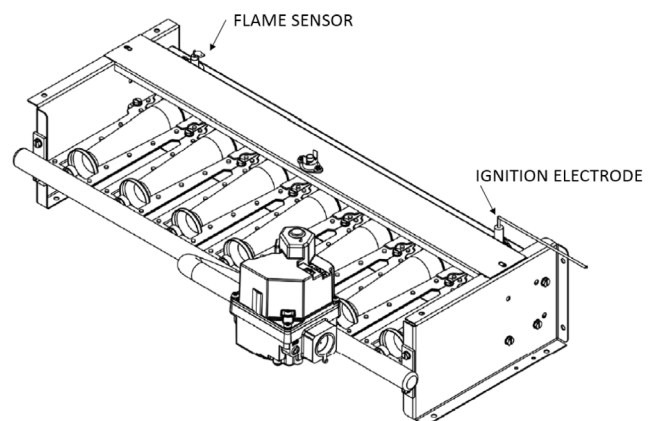

**FLAME SENSOR AND IGNITION ELECTRODE LOCATION**

**FIGURE 13**

| Ton  | Model  | High Fire Rate Btu/Hr | No. of Burners | N.G. Orifice Drill # | L.P. Orifice Drill # |
|------|--------|-----------------------|----------------|----------------------|----------------------|
| 7.5  | DSG090 | 130,000               | 5              | 41                   | 54                   |
|      |        | 180,000               | 6              | 37                   | 53                   |
|      |        | 225,000               | 7              | 36                   | 52                   |
| 8.5  | DSG102 | 130,000               | 5              | 41                   | 54                   |
|      |        | 180,000               | 6              | 37                   | 53                   |
|      |        | 225,000               | 7              | 36                   | 52                   |
| 10   | DSG120 | 130,000               | 5              | 41                   | 54                   |
|      |        | 180,000               | 6              | 37                   | 53                   |
|      |        | 240,000               | 7              | 36                   | 52                   |
| 12.5 | DSG150 | 130,000               | 5              | 41                   | 54                   |
|      |        | 180,000               | 6              | 37                   | 53                   |
|      |        | 240,000               | 7              | 36                   | 52                   |

#### HEAT EXCHANGER AND BURNER ORIFICE SPECIFICATIONS

**NOTE: GAS APPLIANCES LOCATED MORE THAN 2000 FEET ABOVE SEA LEVEL MUST BE DERATED 4% PER 1000 FEET OF TOTAL ELEVATION AND THAT VARIANCE IN GAS HEATING VALUE AND SPECIFIC GRAVITY REQUIRE CHANGE IN MANIFOLD PRESSURE TO OBTAIN RATING, IT IS MANDATORY THAT THE INPUT BE ADJUSTED AT THE INSTALLATION SITE. ALL INSTALLATIONS SHOULD BE MADE AS OUTLINED IN THE LATEST EDITION OF THE NATIONAL FUEL GAS CODE ANSI Z223.1, SECTION "PROCEDURES TO BE FOLLOWED TO PLACE AN APPLIANCE IN OPERATION". REFER ALSO TO THE "USER'S INFORMATION MANUAL" SUPPLIED WITH THE UNIT FOR ADDITIONAL INFORMATION ON THE GAS FURNACE.**

#### GAS SUPPLY AND MANIFOLD CHECK

Gas supply pressure and manifold pressure with the burners operating must be as specified on the rating plate.

#### GAS INLET PRESSURE CHECK

Gas inlet pressure must be checked and adjusted in accordance to the type of fuel being consumed.

#### PRE-OPERATION CHECKS

1. Close the manual gas valve external to the unit.
2. Turn off the electrical power supply to the unit.
3. Change heating setpoint to its lowest possible setting.
4. Remove the heat exchanger door on the side of the unit by removing screws.
5. This unit is equipped with an ignition device which automatically lights the main burner. DO NOT try to light burner by any other method.
6. Move the gas control valve switch to the OFF position.
7. Wait five minutes to clear out any gas.
8. Smell for gas, including near the ground. This is important because some types of gas are heavier than air. If you have waited five minutes and you do smell gas, immediately follow the warning WHAT TO DO IF YOU SMELL GAS on page 2 of this manual. If having waited for five minutes and no gas smell is noted, move the gas control valve switch to the ON position.

9. Replace the heat exchanger door on the side of the unit.
10. Open the manual gas valve external to the unit.
11. Turn on the electrical power supply to the unit.
12. Change heating setpoint to desired setting.

#### WITH POWER AND GAS OFF:

1. Connect a water manometer or adequate gauge to the inlet pressure tap of the gas valve.

Inlet gas pressure can also be measured by removing the cap from the dripleg and installing a predrilled cap with a hose fitting.

**NOTE: BEFORE REMOVING THE CAP ON THE DRIP LEG TURN OFF THE MAIN GAS VALVE.**

#### WITH POWER AND GAS ON:

2. Put unit into heating cycle and turn on all other gas consuming appliances.

| INLET GAS PRESSURE |                                  |
|--------------------|----------------------------------|
| NATURAL            | Min. 5.0" W.C., Max. 10.0" W.C.  |
| PROPANE            | Min. 11.0" W.C., Max. 14.0" W.C. |

**NOTE: INLET GAS PRESSURE MUST BE WITHIN LIMITS SHOWN ABOVE.**

If operating pressures differ from above, make necessary pressure regulator adjustments, check piping size, etc., and/or consult with local utility.

#### MANIFOLD PRESSURE CHECK AND ADJUSTMENT

The gas valve has a pressure tap to facilitate measurement of the manifold pressure. The manifold pressure must be measured with the burners operating.

1. With disconnect switch open, remove field connected thermostat wire from terminal R, W1 and W2 on TB1. Place jumper wire between R, W1 and W2 to engage high stage heat.
2. See Figure in gas input check section for gas valve adjustment.

To adjust the pressure regulator, remove the adjustment screw cover on the gas valve. Turn the adjustment screw out (counterclockwise) to decrease pressure, turn in (clockwise) to increase pressure. Only small variations in gas flow should be made by means of the pressure regulator adjustment. Any major changes in flow should be made by changing the size of the burner orifices. The measured input rate to the furnace must not exceed the rating specified on the unit rating plate.

For natural gas, the high stage manifold pressure must be between 3.2 and 3.8 inches water column (3.5 nominal). Low stage manifold pressure must be between 1.7 to 2.3 inches water column (2.0 nominal).

- To set low fire rate, open disconnect switch and remove jumper from R to W2. To set low fire manifold pressure, repeat steps above. Refer to Figure in gas input check section for location of high and low stage pressure adjustment.

For propane gas, the manifold pressure must be between 9.7 and 10.3 inches water column (10.0 nominal). Low stage manifold must be between 5.7 and 6.3 inches water column (6.0 nominal).

### **GAS INPUT (NATURAL GAS ONLY) CHECK**

It is the responsibility of the contractor to adjust the gas input to the unit.

To measure the gas input use a gas meter and proceed as follows:

- Turn off gas supply to all other appliances except the unit.
- With the unit operating, time the smallest dial on the meter for one complete revolution. If this is a 2 cubic foot dial, divide the seconds by 2; if it is a 1 cubic foot dial, use the seconds as is. This gives the seconds per cubic foot of gas being delivered to the unit.
- $INPUT = GAS\ HTG\ VALUE \times 3600 / SEC.\ PER\ CUBIC\ FOOT$

**Example:** Natural gas with a heating value of 1000 BTU per cubic foot and 34 seconds per cubic foot as determined by Step 2, then:

$$Input = 1000 \times 3600 / 34 = 106,000 \text{ BTU per Hour.}$$

**NOTE: BTU CONTENT OF THE GAS SHOULD BE OBTAINED FROM THE GAS SUPPLIER. THIS MEASURED INPUT MUST NOT BE GREATER THAN SHOWN ON THE UNIT RATING PLATE.**

Adjust input rate by varying the adjustment of the gas pressure regulator on the gas valve. All adjustments must be made with furnace operating at high fire and at normal operating temperature. A manometer should be connected to the gas valve to verify pressure is within the specified range (see following figures for manometer connections). Clockwise rotation of the pressure regulator screw increases pressure and gas flow rate. Turn screw counterclockwise to decrease pressure and gas flow rate. After adjustment the furnace temperature rise must be within the range specified on the unit data plate.

**NOTE: THERMAL EFFICIENCY OF THE FURNACE IS A PRODUCT EFFICIENCY RATING DETERMINED UNDER CONTINUOUS OPERATING CONDITIONS INDEPENDENT OF ANY INSTALLED SYSTEM.**

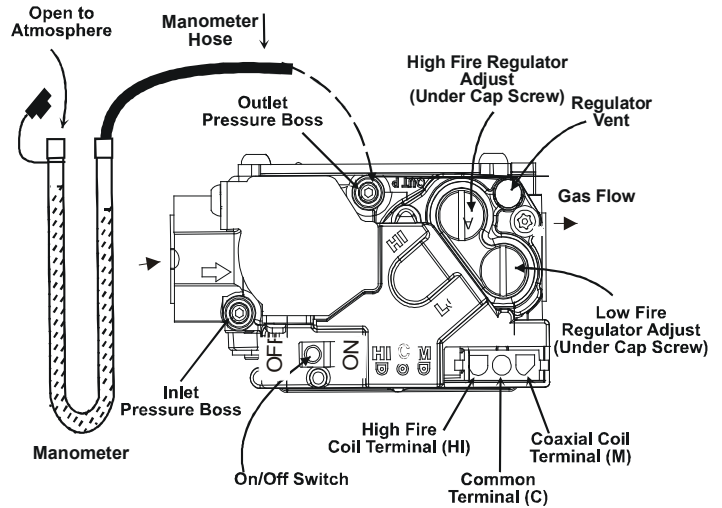

**WHITE-RODGERS (2-STAGE) GAS CONTROL VALVE  
CONNECTED TO MANOMETER PRESSURE ADJUSTMENTS  
FIGURE 14**

To connect manometer to gas valve:

- Back outlet pressure tap screw (inside inlet pressure boss) out one turn (counterclockwise, not more than one turn).
- Attach a hose and manometer to the outlet pressure boss of the valve.

To remove manometer from gas valve:

- Remove manometer hose from outlet pressure boss.
- Turn outlet pressure tap screw in to seal pressure port (clockwise, 7 in-lb. minimum).
- Turn on electrical power and gas supply to the system.
- Turn on system power and energize valve.
- Using a leak detection solution or soap suds, check for leaks at pressure boss screw. Bubbles forming indicate a leak. SHUT OFF GAS AND FIX ALL LEAKS IMMEDIATELY.



### **CAUTION**

**TO PREVENT UNRELIABLE OPERATION OR EQUIPMENT DAMAGE, THE GAS MANIFOLD PRESSURE MUST BE AS SPECIFIED ON THE UNIT RATING PLATE. ONLY MINOR ADJUSTMENTS SHOULD BE MADE BY ADJUSTING THE GAS VALVE PRESSURE REGULATOR.**

- Relight all other appliances turned off in step 1 of gas input check. Be sure all pilot burners are operating.

### **MAIN BURNER FLAME CHECK**

Flames should be stable, soft and blue (dust may cause orange tips but they must not be yellow) and extending directly outward from the burner without curling, floating or lifting off.

## NOx SCREEN CHECK

Verify that the alignment of the NOx screens is at 6 o'clock. In jurisdictions that do not require low NOx emissions, NOx screens may be removed.

## TEMPERATURE RISE CHECK

Check the temperature rise through the unit by placing thermometers in supply and return air registers as close to the unit as possible. Thermometers must not be able to sample temperature directly from the unit heat exchangers, or false readings could be obtained.

1. All registers must be open; all duct dampers must be in their final (fully or partially open) position and the unit operated for 15 minutes before taking readings
2. The temperature rise must be within the range specified on the rating plate.

### **NOTE: AIR TEMPERATURE RISE IS THE TEMPERATURE DIFFERENCE BETWEEN SUPPLY AND RETURN AIR.**

With a properly designed system, the proper amount of temperature rise will normally be obtained when the unit is operated at rated input with the recommended blower speed.

If the correct amount of temperature rise is not obtained, it may be necessary to change the blower speed. A higher blower speed will lower the temperature rise. A slower blower speed will increase the temperature rise.

### **NOTE: BLOWER SPEED MUST BE SET TO GIVE THE CORRECT AIR TEMPERATURE RISE THROUGH THE UNIT AS MARKED ON THE RATING PLATE.**

## NORMAL SEQUENCE OF OPERATION

### HEATING

#### **NOTE: ON UNITS WITH THE DDC CONTROLS OPTION INSTALLED, REFER TO THE DDC CONTROLLER USER MANUAL FOR SEQUENCE OF OPERATION DETAILS.**

This unit has one (RS) Manual Reset Limit Control Switch. Check the limit to make sure it has not tripped. The limit may arrive at the job site tripped as a result of shipping shock.

If the venter motor comes on, but the unit does not attempt ignition, check if the ALS (Auxiliary High Limit Control Switch) requires resetting.

1. With electricity and gas turned on, the system switch in the "HEAT" or "AUTO" position and the fan switch in the "AUTO" position, the thermostat will close the circuit between unit terminals R and W (R-W) when the temperature falls below the thermostat setting.
2. D1 on IIC energizes venter motor contactor.
3. Venter motor contactor energizes the venter motor.
4. Operation of the venter motor closes the pressure switch PS located in the burner compartment.

Unless excessive temperatures or shipping shock have opened high limit control ALS, power is fed to the integrated ignition control, which then initiates a 15-second pre-purge time delay. During this period, the venter fan will clear the combustion chamber of any residual gas.

5. After the pre-purge period, the ignition control energizes the WI-C gas valve and simultaneously initiates a "three (3)-try" spark ignition sequence.
6. When the burners are ignited, a minimum one (1) micro-amp DC current will flow through the flame between the sensor electrode and the grounded burner.
7. When the controller proves that the flame has been established, it will keep the gas valve energized and discontinue the ignition spark.
8. If the control is unable to ignite the burners after its initial attempt, it will initiate another purge and spark sequence. A third purge and spark sequence will be initiated if the second attempt is unsuccessful. If the third attempt is unsuccessful, the controller will close the gas valve and lock itself out. It may be reset by momentarily interrupting power. This may be accomplished by briefly lowering the room thermostat set-point below room temperature, or by shutting off the main power to the unit.
9. Integrated ignition control will close its normally open contacts after a delay of approximately 30 seconds. This action energizes the blower motor contactor and starts the supply fan motor. Operation of the supply fan circulates air across the heat exchanger and delivers heated air to the conditioned space.
10. When the space temperature rises, the thermostat will open R-W. Opening R-W will cause the gas valve to close, and the furnace to shut down.
11. The furnace has three high temperature limit controls, which can shut down the burner. They do not shut down the venter motor.

### UNIT SHUTDOWN

1. Set the room heating setpoint to lowest setting.
2. Turn off the electrical power supply to the unit.
3. Remove the heat exchanger door on the side of the unit by removing screws.
4. Move the gas control valve switch to the OFF position.
5. Close manual gas shut off valve external to the unit.
6. Replace the heat exchanger door on the unit.
7. If cooling and/or air circulation will be desired, turn ON gas control valve switch and the electrical power.

### AUTOMATIC RESET HIGH LIMIT CONTROL (LS)

Located in the burner compartment on the heat exchanger, its sensing element projects through the blower section bulkhead and senses the temperature at the rear of the furnace. It will cycle the furnace off if the temperature exceeds 100°F plus maximum rise.

### AUXILIARY HIGH LIMIT CONTROL (ALS)

Located in the blower compartment on the blower housing,



it senses air temperature within the blower compartment and protects the filters from excessive temperature. It will shut down the furnace if it senses excessive temperatures.

Elevated temperatures at the control are normally caused by blower failure. The reason for the shut down should be determined and repaired prior to resetting.

#### **MANUAL RESET FLAME ROLLOUT CONTROL (RS)**

Located in the burner compartment at the top of the burner assembly, it senses high temperature that could occur if the heat exchanger tubes were plugged and the flame was rolling out instead of entering the tubes. It has a manual push-button reset that cannot be actuated until the limit control has cooled.

The reason for elevated temperatures at the control should be determined and repaired prior to resetting this manual reset control.

#### **RDS FUNCTION**

The mitigation system is a stationary device that detects the presence of R-32 refrigerant above 25% LFL using refrigerant sensors and then initiates mitigation actions. The mitigation system's primary function is to reduce the concentration of leaked R-32 refrigerant to prevent serious safety hazards. The mitigation actions are accomplished by halting HVAC operation and continuing indoor blower operation to provide airflow. Once refrigerant concentration reaches below a safe threshold, the unit will remain in mitigation mode for five minutes to evacuate any remaining R-32 refrigerant within the unit. Upon completion, the unit will resume its normal operation.

#### **RDS OPERATION**

The mitigation system is controlled by a refrigerant sensor(s), which is secured to a designated location(s) for active monitoring. If a leak is detected, HVAC operation is disabled and the indoor blower fan is activated, providing airflow at or above minimum required airflow to evacuate excess concentration. If a Zone Control system is installed in the ductwork attached to this system, the Zone controller must be powered through a Daikin Zoning/Accessory PCB to ensure that the Zoning Dampers open during mitigation mode to provide ventilation throughout all ducting. If the unit is installed with a communicating thermostat, the thermostat will display relevant alerts/information concerning mitigation mode. Once sensors read concentration levels below a safe threshold, a five-minute timer will initiate. Once the time is over, the unit will resume back to its normal operation. If the sensors detect another concentration excess, the unit will go back into mitigation mode and will repeat the same process.



### **WARNING**

**TO AVOID PROPERTY DAMAGE, PERSONAL INJURY OR DEATH DUE TO FIRE OR EXPLOSION, A QUALIFIED SERVICER MUST INVESTIGATE THE REASON FOR THE ROLLOUT PROTECTION DEVICE TO OPEN BEFORE MANUALLY RESETTING THE ROLLOUT PROTECTION DEVICE.**

#### **REFRIGERATION SYSTEM CHECKS**

This unit is equipped with thermal expansion valves.

Ensure the hold-down bolts on the compressor are secure and have not vibrated loose during shipment. Check that the vibration grommets have been installed and visually check all piping for damage and leaks and repair if necessary. The entire system has been factory charged and tested, making it unnecessary to field charge. Factory refrigerant charge is shown on the unit's nameplate.

To confirm charge levels or, if a leak occurs and charge needs to be added to the system, it is recommended to evacuate the system and recharge refrigerant to the unit's nameplate specifications. This unit has been rated in the cooling mode at the AHRI rated conditions of: indoor (80°F db/67°F wb) and outdoor (95°F db). While operating at this condition, the superheat should range from 9°F to 11°F for each refrigeration circuit measured at the suction service port located near the compressor.

#### **START-UP PROCEDURE AND CHECKLIST**

Begin with power turned off at all disconnects.

1. Turn thermostat system switch to "Cool," and fan switch to "Auto" and turn temperature setting as high as it will go.
2. Inspect all registers and set them to the normal open position.
3. Turn on the electrical supply at the disconnect.
4. Turn the fan switch to the "ON" position. The blower should operate after a 7 second delay.
5. Turn the fan switch to "Auto" position. The blower should stop after a 60 second delay.
6. Slowly lower the cooling temperature until first stage COOL (LOW COOL) starts. The blower, both fans, and first stage compressor should now be operating. Allow the unit to run 10 minutes, make sure cool air is being supplied by the unit.
7. Lower the cooling temperature further until second stage COOL (HIGH COOL) starts. The blower, both fans, and both compressors should now be operating. Allow the unit to run 10 minutes, make sure cool air is being supplied by the unit.
8. Turn the temperature setting to the highest position, stopping the unit. The indoor blower will continue to run for 60 seconds.
9. Turn the thermostat system switch to "OFF" and disconnect all power when servicing the unit.

### REFRIGERATION SEQUENCE CHECK

With the disconnect switch open, remove the field connected thermostat wire from terminal R on TB1 terminal block. Place a jumper across terminals R and G, and across R and Y on TB1 terminal block. Close the disconnect switch. The following operational sequence should be observed.



1. Current through primary winding of transformer TRANS1 energizes the 24-volt control circuit.
2. To simulate a mechanical call for cooling from the wall thermostat, place a jumper across terminals R and Y1 of terminal block TB1.
3. **UNIT WITH ECONOMIZER OPTION:** The compressor circuit is interlocked through terminals 3 and 4 of the economizer module. If the outdoor air enthalpy (temperature and humidity) is not suitable for cooling, the economizer terminals will be closed permitting compressor to be energized.
4. The belt drive blower contactor closes its contacts L1, L2 and L3 to T1, T2 and T3 to provide power to the supply fan motor.
5. Supply fan rotation should not be used to identify proper phasing of the unit. For phasing, please refer to step 7 below. If the supply fan is rotating in the wrong direction, please contact your local distributor or tech services for instructions.
6. Compressor contactor closes its contacts L1, L2 and L3 to T1, T2 and T3 to provide power to the compressor motor COMP 1; COMP 2, if conditions are correct. In addition, contactor C1 closes its contact L3 to T3, energizing the condenser fan motor.

|  |
|--|
|  <b>WARNING</b> |
| <b>BURN HAZARD!<br/>DO NOT TOUCH! DISCHARGE LINE MAY BE HOT!</b>                                   |

7. Check that each compressor is operating correctly. The scroll compressors in these units **MUST** operate in the proper rotation. To ensure the compressors are operating in the correct direction, check the compressor discharge line pressure or temperature after each compressor is started. The discharge pressure and discharge line temperature should increase. If this does not occur and the compressor is producing an exceptional amount of noise, perform the following checks.
  - Ensure all compressors and the supply fan motor are operating in the proper direction. If a single motor is operating backwards, check the power wiring for that motor and correct any leads that have been interchanged at the contactor or at the motor.

- If all of the motors are operating backward, disconnect the unit power supply and lock it in the "OFF" position. Switch two leads of the power supply at the unit Single Point Power Block. Reconnect power and check for compressor and supply fan motor operation.
8. With all safety devices closed, the system will continue cooling operation until the thermostat is satisfied.
  9. Disconnecting the jumper wire between R and Y1 and Y2 and between R and G on TB1 terminal block will simulate a satisfied thermostat. The compressors will cycle off and IIC (pin 12) will initiate its time delay cycle. The compressor and the supply fan will cycle off.
  10. After a time delay of approximately 3 minutes, the compressor control circuits will be ready to respond to a subsequent call for cooling from the wall thermostat.
  11. Open disconnect switch. Reconnect the field thermostat wire at terminal R on terminal block TB1.

**NOTE: WHILE IN THE COOLING MODE, TO PREVENT FROST FROM FORMING ON THE EVAPORATOR WHILE THE UNIT IS OPERATING IN OUTDOOR TEMPERATURES OF 65°F OR LOWER, IT IS RECOMMENDED THAT A LOW AMBIENT KIT (LAKT-\*\*) IS USED. THIS IS STRONGLY RECOMMENDED FOR 2 SPEED MODELS DUE TO THE LOWER AIRFLOW WHILE IN THE FIRST STAGE COOLING. TO FURTHER PROTECT THE COMPRESSOR FROM DAMAGE DURING LOW AMBIENT CONDITIONS, A FREEZESTAT KIT (FSK01) CAN BE ADDED THAT TURNS THE COMPRESSOR OFF WHEN THE EVAPORATOR TEMPERATURE DROPS TOO LOW.**

|  |   |
|--|---|
|  <b>WARNING</b>   |   |
| <b>HIGH VOLTAGE!<br/>DISCONNECT ALL POWER BEFORE<br/>SERVICING OR INSTALLING THIS UNIT.<br/>MULTIPLE POWER SOURCES MAY BE<br/>PRESENT. FAILURE TO DO SO MAY CAUSE<br/>PROPERTY DAMAGE, PERSONAL INJURY OR<br/>DEATH.</b> |  |

### FINAL SYSTEM CHECKS

1. Check to see if all supply and return air grilles are adjusted and the air distribution system is balanced for the best compromise between heating and cooling.
2. Check for air leaks in the ductwork. See Sections on Air Flow Adjustments.
3. Make sure the unit is free of "rattles", and the tubing in the unit is free from excessive vibration. Also make sure tubes or lines are not rubbing against each other or sheet metal surfaces or edges. If so, correct the trouble.
4. Set the thermostat at the appropriate setting for cooling and heating or automatic changeover for normal use.
5. Be sure the Owner is instructed on the unit operation, filter, servicing, correct thermostat operation, etc.

## REFRIGERATION PERFORMANCE CHECK

Check that compressor RLA corresponds to values shown in Appendix B. RLA draw can be much lower than values listed at low load conditions and low ambient condensing temperatures. Values in Appendix B can slightly exceed at high load conditions and high ambient condensing temperatures.

## CHECKING SUBCOOLING

**NOTE: MAKE SURE THE AIR FLOW IS CORRECT BEFORE MAKING ANY ADJUSTMENTS. UNITS WITH A TXV SHOULD BE CHARGED TO SUBCOOLING ONLY.**

EXAMPLE:

- Liquid Line Pressure = 417 PSI
- Corresponding Temp. = 120°F
- Thermometer on Liquid line = 109°F.

To obtain the amount of subcooling, subtract 109°F from 120°F. The difference is 11° subcooling. See the specification sheet or technical information manual for the design subcooling range for your unit.

**SUBCOOLING FORMULA = SATURATED LIQUID LINE TEMPERATURE - LIQUID LINE TEMPERATURE**

## CHECKING SUPERHEAT

EXAMPLE:

- Suction Pressure = 143 PSI
- Corresponding Temp. = 50°F
- Thermometer on Suction Line = 59°F

To obtain the degrees temperature of superheat, subtract 50.0 from 59.0°F. The difference is 9° Superheat. The 9° Superheat would fall in the ± range of allowable superheat.

**SUPERHEAT = SUCTION LINE TEMP - SAT. SUCTION TEMP.**

## SUPERHEAT ADJUSTMENT

**NOTE: SUPERHEAT ADJUSTMENTS SHOULD NOT BE MADE UNTIL INDOOR AMBIENT CONDITIONS HAVE STABILIZED. THIS COULD TAKE UP TO 24 HOURS DEPENDING ON INDOOR TEMPERATURE AND HUMIDITY. BEFORE CHECKING SUPERHEAT, RUN THE UNIT IN COOLING FOR 15-20 MINUTES OR UNTIL REFRIGERANT PRESSURES STABILIZE. USE THE FOLLOWING GUIDELINES AND METHODS TO CHECK UNIT OPERATION AND ENSURE THAT THE REFRIGERANT CHARGE IS WITHIN LIMITS.**

For TXV systems, to adjust superheat, unscrew the cover from the expansion valve, locate the adjustment screw, and turn it clockwise (in) to increase superheat or counterclockwise (out) to decrease superheat. It is recommended to make small adjustments at a time, 1/8-1/4 turn increments. Replace adjustment cap. Wait a minimum of 15 minutes between adjustments to allow time for the TXV and pressures to stabilize.

## CHECKING SUBCOOLING

**NOTE: UNITS WITH A TXV SHOULD BE CHARGED TO SUBCOOLING ONLY. MAKE SURE THE AIR FLOW IS CORRECT BEFORE MAKING ANY ADJUSTMENTS.**

EXAMPLE:

- Liquid Line Pressure = 417 PSI
- Corresponding Temp. = 120°F
- Thermometer on Liquid line = 109°F.

**TO OBTAIN THE AMOUNT OF SUBCOOLING, SUBTRACT 109°F FROM 120°F. THE DIFFERENCE IS 11° SUBCOOLING.**

**SEE THE SPECIFICATION SHEET OR TECHNICAL INFORMATION MANUAL FOR THE DESIGN SUBCOOLING RANGE FOR YOUR UNIT.**

**SUBCOOLING FORMULA = SATURATED LIQUID LINE TEMPERATURE - LIQUID LINE TEMPERATURE**

EXAMPLE:

- Suction Pressure = 143 PSI
- Corresponding Temp. = 50°F
- Thermometer on Suction Line = 59°F

**TO OBTAIN THE DEGREES TEMPERATURE OF SUPERHEAT, SUBTRACT 50.0 FROM 59.0°F. THE DIFFERENCE IS 9° SUPERHEAT. THE 9° SUPERHEAT WOULD FALL IN THE ± RANGE OF ALLOWABLE SUPERHEAT.**

**SUPERHEAT = SUCTION LINE TEMP - SAT. SUCTION TEMP.**

## SUPERHEAT ADJUSTMENT

**NOTE: SUPERHEAT ADJUSTMENTS SHOULD NOT BE MADE UNTIL INDOOR AMBIENT CONDITIONS HAVE STABILIZED. THIS COULD TAKE UP TO 24 HOURS DEPENDING ON INDOOR TEMPERATURE AND HUMIDITY. BEFORE CHECKING SUPERHEAT, RUN THE UNIT IN COOLING FOR 15-20 MINUTES OR UNTIL REFRIGERANT PRESSURES STABILIZE. USE THE FOLLOWING GUIDELINES AND METHODS TO CHECK UNIT OPERATION AND ENSURE THAT THE REFRIGERANT CHARGE IS WITHIN LIMITS.**

For TXV systems, to adjust superheat, unscrew the cover from the expansion valve, locate the adjustment screw, and turn it clockwise (in) to increase superheat or counterclockwise (out) to decrease superheat. It is recommended to make small adjustments at a time, 1/8-1/4 turn increments. Replace adjustment cap. Wait a minimum of 15 minutes between adjustments to allow time for the TXV and pressures to stabilize.

## REFRIGERANT CHARGE CHECK

**NOTE: FOR OPTIMAL PERFORMANCE, FOLLOW CHARGING INSTRUCTIONS BELOW.**

### (UNITS WITH FIXED ORIFICE DEVICES)

All package units with fixed orifice devices are charged using the superheat method at the compressor suction line. To increase super heat, remove charge and to decrease super heat, add charge. After superheat is adjusted, it is recommended to check unit subcooling at the condenser coil liquid line. See Design Superheat and Subcooling table for targets on each model.

### (UNITS WITH EXPANSION VALVE (TXV))

Run unit on High Stage cooling and refer to Design Superheat & Subcooling table

1. Purge gauge lines. Connect service gauge manifold to access fittings. Run system at least 10 minutes to allow pressure to stabilize.
2. Temporarily install thermometer on liquid (small) line near liquid line access fitting with adequate contact and insulate for best possible reading.
3. Check subcooling and superheat. System should have a subcooling and superheat within the range listed on the Design Superheat and Subcooling table.
  - a. If subcooling and superheat are low, adjust TXV superheat, then check subcooling.  
**NOTE: To ADJUST SUPERHEAT, TURN THE VALVE STEM CLOCKWISE TO INCREASE AND COUNTERCLOCKWISE TO DECREASE.**
  - b. If subcooling is low and superheat is high, add charge to raise subcooling then check superheat.
  - c. If subcooling and superheat are high, adjust TXV valve superheat, then check subcooling.
  - d. If subcooling is high and superheat is low, adjust TXV valve superheat and remove charge to lower the subcooling.

NOTE: Do NOT adjust the charge based on suction pressure unless there is a gross undercharge. If an under charge is suspected recover the charge, re-evacuate the system and recharge per data plate. No adjustments should be made if suspecting a charge issue.

4. Disconnect manifold set, installation is complete.

| Design Superheat and Subcooling |                                |                                     |                     |                  |                            |
|---------------------------------|--------------------------------|-------------------------------------|---------------------|------------------|----------------------------|
| Model                           | Superheat<br>±2°F<br>(Circuit) | Subcooling<br>±1°F<br>(Circuit 1/2) | Expansion<br>Device | Cooling<br>Stage | Outdoor<br>ambient<br>(°F) |
| DSG090*                         | 17/16                          | 13/14                               | TXV                 | High             | 95                         |
| DSG102*                         | 16.3/18.9                      | 11.1/11.7                           | TXV                 | High             | 95                         |
| DSG120*                         | 19/22                          | 9/6                                 | TXV                 | High             | 95                         |
| DSG150*                         | 16/18                          | 12/12                               | TXV                 | High             | 95                         |

## MAINTENANCE



### WARNING

**ELECTRICAL SHOCK, FIRE OR EXPLOSION HAZARD**  
**FAILURE TO FOLLOW SAFETY WARNINGS EXACTLY COULD RESULT IN DANGEROUS OPERATION, SERIOUS INJURY, DEATH OR PROPERTY DAMAGE.**

**IMPROPER SERVICING COULD RESULT IN DANGEROUS OPERATION, SERIOUS INJURY, DEATH OR PROPERTY DAMAGE.**

- **BEFORE SERVICING, DISCONNECT ALL ELECTRICAL POWER TO FURNACE.**
- **WHEN SERVICING CONTROLS, LABEL ALL WIRES PRIOR TO DISCONNECTING. RECONNECT WIRES CORRECTLY.**
- **VERIFY PROPER OPERATION AFTER SERVICING.**



### WARNING

**HIGH VOLTAGE!**  
**DISCONNECT ALL POWER BEFORE SERVICING OR INSTALLING THIS UNIT. MULTIPLE POWER SOURCES MAY BE PRESENT. FAILURE TO DO SO MAY CAUSE PROPERTY DAMAGE, PERSONAL INJURY OR DEATH.**



### WARNING

**TO PREVENT PERSONAL INJURY OR DEATH DUE TO IMPROPER INSTALLATION, ADJUSTMENT, ALTERATION, SERVICE OR MAINTENANCE, REFER TO THIS MANUAL. FOR ADDITIONAL ASSISTANCE OR INFORMATION, CONSULT A QUALIFIED INSTALLER, SERVICER AGENCY OR THE GAS SUPPLIER.**



### CAUTION

**SHEET METAL PARTS, SCREWS, CLIPS AND SIMILAR ITEMS INHERENTLY HAVE SHARP EDGES, AND IT IS NECESSARY THAT THE INSTALLER AND SERVICE PERSONNEL EXERCISE CAUTION.**

Preventive maintenance is the best way to avoid unnecessary expense and inconvenience. Have this system inspected at regular intervals by qualified service personnel, at least twice a year. Routine maintenance should cover the following items:

1. Tighten all set screws, and wire connections.
2. Clean evaporator and condenser coils mechanically or with cold water, if necessary. Usually any fouling is only matted on the entering air face of the coil and can be removed by brushing.
3. Replace filters as needed (see Filters section).
4. Check for blockage of condensate drain.
5. Check power and control voltages.

6. Check running amperage.
7. Check operating temperatures and pressures.
8. Check and adjust temperature and pressure controls.
9. Check and adjust damper linkages.
10. Check operation of all safety controls.
11. Examine gas furnaces (see below and the User's Information Manual).
12. Check condenser fans and tighten set screws.

## FILTERS



### CAUTION

**TO PREVENT PROPERTY DAMAGE DUE TO FIRE AND LOSS OF EQUIPMENT EFFICIENCY OR EQUIPMENT DAMAGE DUE TO DUST AND LINT BUILD UP ON INTERNAL PARTS, NEVER OPERATE UNIT WITHOUT AN AIR FILTER INSTALLED IN THE RETURN AIR SYSTEM.**

Every application may require a different frequency of replacement of dirty filters. Filters must be replaced at least every three (3) months during operating seasons.

Dirty filters are the most common cause of inadequate heating or cooling performance. Filter inspection should be made at least every two months; more often if necessary because of local conditions and usage.

Dirty throwaway filters should be discarded and replaced with a new, clean filter.

Disposable return air filters are supplied with this unit. See the unit Specification Sheet or Technical Manual for the correct size and part number. To remove the filters, remove the filter access panel on return side of the unit.

### CABINET FINISH MAINTENANCE

Use a fine grade automotive wax on the cabinet finish to maintain the finish's original high luster. This is especially important in installations with extended periods of direct sunlight.

### CLEAN OUTSIDE COIL

The coil with the outside air flowing over it should be inspected annually and cleaned as frequently as necessary to keep the finned areas free of lint, hair and debris. Clean coil from inside out.

### CLEAN INDOOR COIL (QUALIFIED SERVICER ONLY)

Before cleaning the indoor coil, A2L sensor must be removed from the unit to avoid damage and contamination. Air filters should also be removed before performing maintenance. The coil with the filtered air flowing over it should be inspected and cleaned as frequently as necessary to keep the finned areas free of debris. Any air blowing or water rinsing should be performed from inside-out (opposite operating airflow direction) to prevent damage to the tube, fin coil and any other components.

## RECOVERY

When removing refrigerant from a system, either for servicing or decommissioning, it is recommended good practice that all refrigerants are removed safely.

When transferring refrigerant into cylinders, ensure that only appropriate refrigerant recovery cylinders are employed. Ensure that the correct number of cylinders for holding the total system charge is available. All cylinders to be used are designated for the recovered refrigerant and labelled for that refrigerant (i.e. special cylinders for the recovery of refrigerant). Cylinders shall be complete with pressure-relief valve and associated shut-off valves in good working order. Empty recovery cylinders are evacuated and, if possible, cooled before recovery occurs.

The recovery equipment shall be in good working order with a set of instructions concerning the equipment that is at hand and shall be suitable for the recovery of the flammable refrigerant. If in doubt, the manufacturer should be consulted. In addition, a set of calibrated weighing scales shall be available and in good working order. Hoses shall be complete with leak-free disconnect couplings and in good condition.

The recovered refrigerant shall be processed according to local legislation in the correct recovery cylinder, and the relevant waste transfer note arranged. Do not mix refrigerants in recovery units and especially not in cylinders.

If compressors or compressor oils are to be removed, ensure that they have been evacuated to an acceptable level to make certain that flammable refrigerant does not remain within the lubricant. The compressor body shall not be heated by an open flame or other ignition sources to accelerate this process. When oil is drained from a system, it shall be carried out safely.

## CHARGING PROCEDURES

In addition to conventional charging procedures, the following requirements shall be followed.

- Ensure that contamination of different refrigerants does not occur when using charging equipment. Hoses or lines shall be as short as possible to minimize the amount of refrigerant contained in them.
- Cylinders shall be kept in an appropriate position according to the instructions.
- Ensure that the REFRIGERATING SYSTEM is earthed prior to charging the system with refrigerant.
- Label the system when charging is complete (if not already).
- Extreme care shall be taken not to overfill the REFRIGERATING SYSTEM.

Prior to recharging the system, it shall be pressure-tested with the appropriate purging gas. The system shall be leak-tested on completion of charging but prior to commissioning. A follow up leak test shall be

## CONDENSER AND INDUCED DRAFT MOTORS

Bearings on the condenser fan motors and the combustion fan motor are permanently lubricated. No additional oiling is required.

## FLAME SENSOR

A drop in the flame current can be caused by a nearly invisible coating on the flame sensor. This coating, created by the fuel or combustion air supply, can be removed by carefully cleaning the flame sensor with steel wool.

**NOTE: AFTER CLEANING, THE MICROAMP SIGNAL SHOULD BE STABLE AND IN THE RANGE OF 4 - 6 MICROAMPS DC.**

## FLUE PASSAGES

At the start of each heating season, inspect and, if necessary, clean the unit flue passage.

## LUBRICATION

The fan shaft bearings, the supply fan motors, the condenser fan motors and compressors are permanently lubricated.

## INSPECTION & CLEANING

All flue product carrying areas of the furnace, its vent system, and main burners should be examined by a qualified service agency, and cleaned if necessary, before the start of each heating season. This examination is necessary for continued safe operation. Particular attention should be given to deterioration from corrosion or other sources. This examination is accomplished in the following manner.

1. Disconnect power to the unit and remove furnace section access panel.
2. Remove burner assembly:
  - a. Disconnect the wires from the gas valve after noting which wires are connected to each terminal.
  - b. Disconnect wires from the flame rod and ignition electrode.
  - c. Disconnect the gas piping at the union.
  - d. The entire burner assembly can now be removed from the unit.

**NOTE: USE ALL SCREWS THAT WERE REMOVED; THEY ARE NECESSARY FOR SAFE AND PROPER OPERATION OF THE UNIT.**

3. Inspect and periodically clean the vent outlet (bird screen) on the access panel.

**NOTE: PERIODIC OBSERVATION OF THE FLAME AND A LOG OF CO<sub>2</sub> MEASUREMENTS ARE RECOMMENDED. THIS WILL AID IN DETERMINING WHETHER THE FURNACE IS OPERATING EFFICIENTLY OR IF THE FURNACE REQUIRES CLEANING.**

Flames should be stable, soft and blue (dust may cause orange tips but must not be yellow). The flames must extend directly outward from the burner without curling, floating or lifting off.

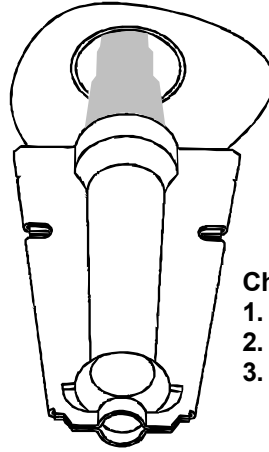

Check the burner flames for:

1. Good adjustment
2. Stable, soft and blue
3. Not curling, floating, or lifting off.

BURNER FLAME  
FIGURE 15



## WARNING

**TO AVOID PERSONAL INJURY OR DEATH DUE TO ELECTRIC SHOCK, DO NOT REMOVE ANY INTERNAL COMPARTMENT COVERS OR ATTEMPT ANY ADJUSTMENT. CONTACT A QUALIFIED SERVICER AT ONCE IF AN ABNORMAL FLAME SHOULD DEVELOP.**

At least once a year, prior to or during the heating season, make a visual check of the burner flames.

**NOTE: THIS WILL INVOLVE REMOVING AND REINSTALLING THE HEAT EXCHANGER DOOR ON THE UNIT, WHICH IS HELD BY TWO SCREWS. IF YOU ARE UNCERTAIN ABOUT YOUR ABILITY TO DO THIS, CONTACT A QUALIFIED SERVICER.**

If a strong wind is blowing, it may alter the airflow pattern within the unit enough that an inspection of the burner flames is not possible.

## FUNCTIONAL PARTS

Refer to the unit Parts Catalog for a list of functional parts. Parts are available from your distributor.

## TROUBLESHOOTING

### IGNITION CONTROL ERROR CODES

The following presents probable causes of questionable unit operation. Refer to *Diagnostic Indicator Chart* for an interpretation of the signal and to this section for an explanation.

Remove the control box access panel and note the number of diagnostic LED flashes.

## **INTERNAL CONTROL FAILURE**

If the integrated ignition control in this unit encounters an internal fault, it will go into a “hard” lockout and turn off the diagnostic LED. If diagnostic LED indicates an internal fault, check power supply to unit for proper voltage, check all fuses, circuit breakers and wiring. Disconnect electric power for five seconds. If LED remains off after restoring power, replace control.

## **ABNORMAL OPERATION - HEATING CODES**

### **EXTERNAL LOCKOUT (1 FLASH CODE)**

An external lockout occurs if the integrated ignition control determines that a measurable combustion cannot be established within three (3) consecutive ignition attempts. If flame is not established within the seven (7) second trial for ignition, the gas valve is deenergized, 15 second inter-purge cycle is completed, and ignition is reattempted. The control will repeat this routine three times if a measurable combustion is not established. The control will then shut off the induced draft blower and go into a lockout state.

If flame is established but lost, the control will energize the circulator blower at the heat speed and then begin a new ignition sequence. If flame is established then lost on subsequent attempts, the control will recycle for four (4) consecutive ignition attempts (five attempts total) before locking out.

The diagnostic fault code is 1 flash for a lockout due to failed ignition attempts or flame dropouts. The integrated control will automatically reset after one hour, or it can be reset by removing the thermostat signal or disconnecting the electrical power supply for over five seconds. If the diagnostic LED indicates an external lockout, perform the following checks:

- *Check the supply and manifold gas pressures*
- *Check the gas orifices for debris*
- *Check gas valve for proper operation*
- *Check secondary limit*

A dirty filter, excessive duct static, insufficient air flow, a faulty limit, or a failed circulator blower can cause this limit to open. Check filters, total external duct static, circulator blower motor, blower motor speed tap (see wiring diagram) and limit. An interruption in electrical power during a heating cycle may also cause the auxiliary limit to open. The automatic reset secondary limit is located on top of the circulator blower assembly.

- *Check rollout limit*

If the burner flames are not properly drawn into the heat exchanger, the flame rollout protection device will open. Possible causes are restricted or blocked flue passages, blocked or cracked heat exchanger, a failed induced draft blower, or insufficient combustion air. The rollout protection device is a manual reset limit located on the burner bracket. The cause of the flame rollout must be determined and corrected before resetting the limit.

- *Check flame sensor*

A drop in flame signal can be caused by nearly invisible coating on the sensor. Remove the sensor and carefully clean with steel wool.

- *Check wiring*

Check wiring for opens/shorts and miswiring.

**IMPORTANT: IF YOU HAVE TO FREQUENTLY RESET YOUR GAS/ELECTRIC PACKAGE UNIT, IT MEANS THAT A PROBLEM EXISTS THAT SHOULD BE CORRECTED. CONTACT A QUALIFIED SERVICER FOR FURTHER INFORMATION.**

### **PRESSURE SWITCH STUCK OPEN (2 FLASH CODE)**

A pressure switch stuck open can be caused by a faulty pressure switch, faulty wiring, a disconnected or damaged hose, a blocked or restricted flue, or a faulty induced draft blower. If the control senses an open pressure switch during the pre-purge cycle, the induced draft blower only will be energized.

If the pressure switch opens after ignition has begun the gas valve is deenergized, the circulator blower heat off cycle begins, and the induced draft blower remains on. The diagnostic fault code is two flashes.

### **PRESSURE SWITCH STUCK CLOSED (3 FLASH CODE)**

A stuck closed pressure switch can be caused by a faulty pressure switch or faulty wiring. If the control encounters a pressure switch stuck closed, the induced draft blower remains off. The diagnostic LED code for this fault is three (3) flashes.

### **OPEN THERMAL PROTECTION DEVICE (4 FLASH CODE)**

If the primary limit switch opens, the gas valve is immediately deenergized, the induced draft and air circulating blowers are energized. The induced draft and air circulator blowers remain energized until the limit switch recloses. The diagnostic fault code for an open limit is four (4) flashes.

A primary limit will open due to excessive supply air temperatures. This can be caused by a dirty filter, excessive duct static, insufficient air flow, or a faulty limit. Check filters, total external duct static, blower motor, blower motor speed tap (see wiring diagram), and limit. This limit will automatically reset once the temperature falls below a preset level.

### **FLAME DETECTED WITH GAS VALVE CLOSED (5 FLASH CODE)**

If flame is detected with the gas valve deenergized, the combustion and air circulator blowers are energized. The diagnostic fault code is five (5) flashes for this condition. The control can be reset by removing the power supply to the unit or it will automatically reset after one hour. Miswiring is the probable cause for this fault.

**ABNORMAL OPERATION - COOLING CODES**

**SHORT CYCLE COMPRESSOR DELAY (6 FLASH CODE)**

The automatic ignition control has a built-in feature that prevents damage to the compressor in short cycling situations. In the event of intermittent power losses or intermittent thermostat operation, the ignition control will delay output to the compressor contactor for three minutes from the time power is restored. (Compressor is off a total of three minutes). The diagnostic LED will flash six (6) times to indicate the compressor contactor output is being delayed.

**NOTE: SOME ELECTRONIC THERMOSTATS ALSO HAVE A BUILT-IN COMPRESSOR SHORT CYCLE TIMER THAT MAY BE LONGER THAN THE THREE MINUTE DELAY GIVEN ABOVE. IF YOU ARE USING AN ELECTRONIC THERMOSTAT AND THE COMPRESSOR HAS NOT STARTED AFTER THREE MINUTES, WAIT AN ADDITIONAL FIVE MINUTES TO ALLOW THE THERMOSTAT TO COMPLETE ITS SHORT CYCLE DELAY TIME.**

**SERVICING MEASURES FOR THE REFRIGERANT DETECTION SYSTEM:**

Before servicing, identify the mode of operation of the system by reading the LED flashing pattern on the PCB within the control box and matching the LED flashing pattern with mode of operation in the REFRIGERANT DETECTION SYSTEM TROUBLESHOOTING GUIDE on the wiring diagram which is attached on the back side of the control box panel (RDS PCB Fault Code table). After identifying the mode of operation, take recommended actions as specified in the Recommended Actions for PCB LED Flashing Codes table.

**REFRIGERANT SENSORS for REFRIGERANT**

DETECTION SYSTEMS shall only be replaced with sensors specified by the manufacturer. If REFRIGERANT SENSOR requires replacement, please replace with Sensata R32 Sensor PN#RGD-00ML12 (Daikin PN#SER2A08011).

| LED STATUS                     |  |
|--------------------------------|--|
| MODE                           | LED FLASHING PATTERN                                   |
| NORMAL OPERATION               | SLOW LED FLASHING PATTERN (2 SECONDS ON 2 SECONDS OFF) |
| R-32 LEAK ALARM                | FAST LED FLASHING PATTERN                              |
| DELAY MODE                     | LED WILL BE ON CONTINUOUSLY                            |
| SYSTEM VERIFICATION MODE       | FAST LED FLASHING PATTERN                              |
| CONTROL BOARD INTERNAL FAULT   | LED WILL FLASH 2 TIMES AND THEN BE OFF FOR 5 SECONDS   |
| R32 SENSOR COMMUNICATION FAULT | LED WILL FLASH 3 TIMES AND THEN BE OFF FOR 5 SECONDS   |
| R32 SENSOR FAULT               | LED WILL FLASH 4 TIMES AND THEN BE OFF FOR 5 SECONDS   |

**RDS PCB Fault Code Table**



# APPENDIX A BLOWER PERFORMANCE DATA

## 7.5 TON GE

7.5T 130K 5 burner Standard Static

Motor 2.4 HP

Model: DSG090\_STD

### DOWNSHOT

### HORIZONTAL

|                       |           | DOWNSHOT |        |        |       |      |  |
|-----------------------|-----------|----------|--------|--------|-------|------|--|
|                       | TAP SPEED | ESP      | SCFM   | R.P.M. | WATTS | BHP  |  |
| PL Rated              | TAP 1     | 0.2      | 2085.3 | 507.0  | 211.3 | 0.33 |  |
|                       |           | 0.4      | 1907.6 | 574.2  | 247.2 | 0.38 |  |
|                       |           | 0.6      | 1720.3 | 640.6  | 269.9 | 0.42 |  |
|                       |           | 0.8      | 1550.1 | 686.7  | 292.5 | 0.45 |  |
| PL Max CFM            | TAP 2     | 0.2      | 2159.2 | 517.7  | 233.9 | 0.37 |  |
|                       |           | 0.4      | 1983.4 | 583.4  | 269.5 | 0.41 |  |
|                       |           | 0.6      | 1800.6 | 648.3  | 292.7 | 0.46 |  |
|                       |           | 0.8      | 1635.7 | 693.7  | 315.9 | 0.49 |  |
| Rated                 | TAP 3     | 0.2      | 3029.7 | 645.0  | 540.9 | 0.85 |  |
|                       |           | 0.4      | 2876.7 | 695.1  | 576.6 | 0.92 |  |
|                       |           | 0.6      | 2739.0 | 743.6  | 605.1 | 0.98 |  |
|                       |           | 0.8      | 2626.8 | 782.0  | 639.7 | 1.03 |  |
| 400 CFM/Ton @ 0.6 ESP | TAP 4     | 0.2      | 3291.4 | 683.9  | 652.8 | 1.05 |  |
|                       |           | 0.4      | 3145.9 | 730.0  | 689.8 | 1.12 |  |
|                       |           | 0.6      | 3018.2 | 774.3  | 716.3 | 1.19 |  |
|                       |           | 0.8      | 2916.9 | 811.4  | 755.2 | 1.25 |  |
| 400 CFM/Ton           | TAP 5     | 0.2      | 3374.1 | 696.2  | 690.7 | 1.12 |  |
|                       |           | 0.4      | 3231.0 | 741.3  | 728.4 | 1.19 |  |
|                       |           | 0.6      | 3106.1 | 784.3  | 759.6 | 1.26 |  |
|                       |           | 0.8      | 3007.6 | 821.0  | 800.6 | 1.32 |  |
|                       | TAP 6     | 0.2      | 1625.0 | 440.9  | 85.1  | 0.16 |  |
|                       |           | 0.4      |        |        |       |      |  |
|                       |           | 0.6      |        |        |       |      |  |
|                       |           | 0.8      |        |        |       |      |  |
|                       | TAP 7     | 0.2      | 1972.4 | 490.7  | 177.6 | 0.18 |  |
|                       |           | 0.4      | 1791.9 | 560.1  | 213.9 | 0.21 |  |
|                       |           | 0.6      | 1597.7 | 628.9  | 236.1 | 0.23 |  |
|                       |           | 0.8      |        |        |       |      |  |
|                       | TAP 8     | 0.2      | 2304.2 | 538.8  | 279.5 | 0.43 |  |
|                       |           | 0.4      | 2132.0 | 601.7  | 314.8 | 0.48 |  |
|                       |           | 0.6      | 1957.7 | 663.6  | 338.8 | 0.53 |  |
|                       |           | 0.8      | 1803.0 | 707.6  | 363.5 | 0.57 |  |
|                       | TAP 9     | 0.2      | 3291.4 | 683.9  | 652.8 | 1.05 |  |
|                       |           | 0.4      | 3145.9 | 730.0  | 689.8 | 1.12 |  |
|                       |           | 0.6      | 3018.2 | 774.3  | 720.3 | 1.19 |  |
|                       |           | 0.8      | 2916.9 | 811.4  | 759.7 | 1.25 |  |
|                       | TAP 10    | 0.2      | 3374.1 | 696.2  | 690.7 | 1.12 |  |
|                       |           | 0.4      | 3231.0 | 741.3  | 728.4 | 1.19 |  |
|                       |           | 0.6      | 3106.1 | 784.3  | 759.6 | 1.26 |  |
|                       |           | 0.8      | 3007.6 | 821.0  | 800.6 | 1.32 |  |

|                       |           | HORIZONTAL |        |        |       |      |  |
|-----------------------|-----------|------------|--------|--------|-------|------|--|
|                       | TAP SPEED | ESP        | SCFM   | R.P.M. | WATTS | BHP  |  |
| PL Rated              | TAP 1     | 0.2        | 2077.0 | 497.6  | 226.7 | 0.33 |  |
|                       |           | 0.4        | 1909.5 | 563.3  | 252.6 | 0.37 |  |
|                       |           | 0.6        | 1715.7 | 629.9  | 284.7 | 0.41 |  |
|                       |           | 0.8        |        |        |       |      |  |
| PL Max CFM            | TAP 2     | 0.2        | 2152.2 | 508.0  | 245.4 | 0.36 |  |
|                       |           | 0.4        | 1986.5 | 572.4  | 271.8 | 0.40 |  |
|                       |           | 0.6        | 1797.3 | 637.5  | 304.7 | 0.45 |  |
|                       |           | 0.8        | 1530.7 | 716.3  | 337.6 | 0.51 |  |
| Rated                 | TAP 3     | 0.2        | 3035.1 | 632.0  | 516.3 | 0.84 |  |
|                       |           | 0.4        | 2892.0 | 682.1  | 549.6 | 0.90 |  |
|                       |           | 0.6        | 2751.6 | 731.5  | 590.8 | 0.97 |  |
|                       |           | 0.8        | 2609.4 | 783.5  | 629.2 | 1.04 |  |
| 400 CFM/Ton @ 0.6 ESP | TAP 4     | 0.2        | 3300.1 | 670.3  | 621.7 | 1.03 |  |
|                       |           | 0.4        | 3164.3 | 716.5  | 657.7 | 1.10 |  |
|                       |           | 0.6        | 3036.2 | 761.8  | 701.2 | 1.17 |  |
|                       |           | 0.8        | 2921.7 | 807.2  | 741.3 | 1.24 |  |
| 400 CFM/Ton           | TAP 5     | 0.2        | 3383.8 | 682.6  | 658.2 | 1.10 |  |
|                       |           | 0.4        | 3250.4 | 727.6  | 695.1 | 1.17 |  |
|                       |           | 0.6        | 3125.8 | 771.6  | 739.3 | 1.24 |  |
|                       |           | 0.8        | 3018.8 | 815.2  | 779.9 | 1.31 |  |
|                       | TAP 6     | 0.2        | 1609.8 | 433.0  | 120.2 | 0.16 |  |
|                       |           | 0.4        |        |        |       |      |  |
|                       |           | 0.6        |        |        |       |      |  |
|                       |           | 0.8        |        |        |       |      |  |
|                       | TAP 7     | 0.2        | 1962.4 | 481.9  | 199.0 | 0.18 |  |
|                       |           | 0.4        | 1792.1 | 549.5  | 224.3 | 0.21 |  |
|                       |           | 0.6        | 1591.2 | 618.3  | 255.2 | 0.23 |  |
|                       |           | 0.8        |        |        |       |      |  |
|                       | TAP 8     | 0.2        | 2299.3 | 528.4  | 283.9 | 0.42 |  |
|                       |           | 0.4        | 2137.3 | 590.3  | 311.2 | 0.47 |  |
|                       |           | 0.6        | 1956.9 | 652.6  | 345.5 | 0.52 |  |
|                       |           | 0.8        | 1713.7 | 726.5  | 379.4 | 0.58 |  |
|                       | TAP 9     | 0.2        | 3300.1 | 670.3  | 621.7 | 1.03 |  |
|                       |           | 0.4        | 3164.3 | 716.5  | 657.7 | 1.10 |  |
|                       |           | 0.6        | 3036.2 | 761.8  | 701.2 | 1.17 |  |
|                       |           | 0.8        | 2921.7 | 807.2  | 741.3 | 1.24 |  |
|                       | TAP 10    | 0.2        | 3383.8 | 682.6  | 658.2 | 1.10 |  |
|                       |           | 0.4        | 3250.4 | 727.6  | 695.1 | 1.17 |  |
|                       |           | 0.6        | 3125.8 | 771.6  | 739.3 | 1.24 |  |
|                       |           | 0.8        | 3018.8 | 815.2  | 779.9 | 1.31 |  |





# APPENDIX A BLOWER PERFORMANCE DATA

## 7.5 TON GE

7.5T 180K 6 burner Standard Static

Motor 2.4 HP

Model: DSG090\_STD

### DOWNSHOT

### HORIZONTAL

|             |           | DOWNSHOT |        |        |       |      |  |
|-------------|-----------|----------|--------|--------|-------|------|--|
|             | TAP SPEED | ESP      | SCFM   | R.P.M. | WATTS | BHP  |  |
| PL Rated    | TAP 1     | 0.2      | 1888.7 | 503.5  | 209.1 | 0.30 |  |
|             |           | 0.4      | 1815.1 | 537.9  | 218.3 | 0.32 |  |
|             |           | 0.6      |        |        |       |      |  |
|             |           | 0.8      |        |        |       |      |  |
| PL Max CFM  | TAP 2     | 0.2      | 2136.4 | 542.3  | 272.9 | 0.41 |  |
|             |           | 0.4      | 2047.0 | 579.6  | 287.7 | 0.44 |  |
|             |           | 0.6      | 1758.1 | 671.8  | 331.1 | 0.51 |  |
|             |           | 0.8      | 1532.3 | 738.8  | 362.7 | 0.56 |  |
| Rated       | TAP 3     | 0.2      | 3034.7 | 682.2  | 580.4 | 0.97 |  |
|             |           | 0.4      | 2904.3 | 726.1  | 612.7 | 1.04 |  |
|             |           | 0.6      | 2771.7 | 769.9  | 644.4 | 1.10 |  |
|             |           | 0.8      | 2624.8 | 819.3  | 690.1 | 1.17 |  |
| 400 CFM/Ton | TAP 4     | 0.2      | 3288.9 | 721.6  | 696.8 | 1.19 |  |
|             |           | 0.4      | 3153.2 | 765.7  | 733.0 | 1.26 |  |
|             |           | 0.6      | 3049.2 | 800.1  | 763.6 | 1.32 |  |
|             |           | 0.8      | 2919.6 | 845.2  | 811.8 | 1.39 |  |
| 400 CFM/Ton | TAP 5     | 0.2      | 3404.2 | 739.4  | 755.3 | 1.29 |  |
|             |           | 0.4      | 3267.3 | 783.3  | 793.2 | 1.37 |  |
|             |           | 0.6      | 3173.1 | 814.3  | 823.7 | 1.42 |  |
|             |           | 0.8      | 3050.3 | 857.6  | 872.7 | 1.50 |  |
|             | TAP 6     | 0.2      | 1705.3 | 474.8  | 166.4 | 0.22 |  |
|             |           | 0.4      | 1644.5 | 506.7  | 171.4 | 0.24 |  |
|             |           | 0.6      |        |        |       |      |  |
|             |           | 0.8      |        |        |       |      |  |
|             | TAP 7     | 0.2      | 2136.4 | 542.3  | 272.9 | 0.25 |  |
|             |           | 0.4      | 2047.0 | 579.6  | 287.7 | 0.27 |  |
|             |           | 0.6      | 1758.1 | 671.8  | 331.1 | 0.31 |  |
|             |           | 0.8      | 1532.3 | 738.8  | 362.7 | 0.35 |  |
|             | TAP 8     | 0.2      | 2536.8 | 604.8  | 393.3 | 0.63 |  |
|             |           | 0.4      | 2425.6 | 646.0  | 416.5 | 0.67 |  |
|             |           | 0.6      | 2215.3 | 714.1  | 453.4 | 0.74 |  |
|             |           | 0.8      | 2027.6 | 772.9  | 492.1 | 0.80 |  |
|             | TAP 9     | 0.2      | 3288.9 | 721.6  | 696.8 | 1.19 |  |
|             |           | 0.4      | 3153.2 | 765.7  | 733.0 | 1.26 |  |
|             |           | 0.6      | 3049.2 | 800.1  | 763.6 | 1.32 |  |
|             |           | 0.8      | 2919.6 | 845.2  | 811.8 | 1.39 |  |
|             | TAP 10    | 0.2      | 3404.2 | 739.4  | 755.3 | 1.29 |  |
|             |           | 0.4      | 3267.3 | 783.3  | 793.2 | 1.37 |  |
|             |           | 0.6      | 3173.1 | 814.3  | 823.7 | 1.42 |  |
|             |           | 0.8      | 3050.3 | 857.6  | 872.7 | 1.50 |  |

|             |           | HORIZONTAL |        |        |       |      |  |
|-------------|-----------|------------|--------|--------|-------|------|--|
|             | TAP SPEED | ESP        | SCFM   | R.P.M. | WATTS | BHP  |  |
| PL Rated    | TAP 1     | 0.2        | 1995.7 | 475.9  | 199.1 | 0.28 |  |
|             |           | 0.4        | 1800.6 | 545.1  | 221.1 | 0.32 |  |
|             |           | 0.6        | 1613.5 | 615.7  | 252.7 | 0.36 |  |
|             |           | 0.8        |        |        |       |      |  |
| PL Max CFM  | TAP 2     | 0.2        | 2249.8 | 511.9  | 258.3 | 0.39 |  |
|             |           | 0.4        | 2067.7 | 575.8  | 285.1 | 0.43 |  |
|             |           | 0.6        | 1892.1 | 640.8  | 317.1 | 0.48 |  |
|             |           | 0.8        | 1623.4 | 722.3  | 352.3 | 0.54 |  |
| Rated       | TAP 3     | 0.2        | 3168.5 | 643.4  | 551.1 | 0.92 |  |
|             |           | 0.4        | 3027.8 | 690.4  | 592.9 | 0.98 |  |
|             |           | 0.6        | 2890.1 | 737.2  | 627.0 | 1.05 |  |
|             |           | 0.8        | 2759.8 | 787.0  | 671.2 | 1.12 |  |
| 400 CFM/Ton | TAP 4     | 0.2        | 3427.5 | 681.0  | 663.9 | 1.12 |  |
|             |           | 0.4        | 3296.4 | 724.0  | 709.2 | 1.19 |  |
|             |           | 0.6        | 3167.9 | 766.5  | 744.1 | 1.26 |  |
|             |           | 0.8        | 3063.1 | 809.5  | 790.1 | 1.33 |  |
| 400 CFM/Ton | TAP 5     | 0.2        | 3544.7 | 698.1  | 721.0 | 1.22 |  |
|             |           | 0.4        | 3417.5 | 739.5  | 767.6 | 1.29 |  |
|             |           | 0.6        | 3292.9 | 780.1  | 803.0 | 1.36 |  |
|             |           | 0.8        | 3196.9 | 820.6  | 849.6 | 1.44 |  |
|             | TAP 6     | 0.2        | 1807.5 | 449.4  | 159.9 | 0.21 |  |
|             |           | 0.4        | 1602.5 | 522.6  | 178.2 | 0.24 |  |
|             |           | 0.6        |        |        |       |      |  |
|             |           | 0.8        |        |        |       |      |  |
|             | TAP 7     | 0.2        | 2249.8 | 511.9  | 258.3 | 0.24 |  |
|             |           | 0.4        | 2067.7 | 575.8  | 285.1 | 0.27 |  |
|             |           | 0.6        | 1892.1 | 640.8  | 317.1 | 0.30 |  |
|             |           | 0.8        | 1623.4 | 722.3  | 352.3 | 0.34 |  |
|             | TAP 8     | 0.2        | 2660.0 | 570.3  | 371.8 | 0.59 |  |
|             |           | 0.4        | 2497.6 | 626.2  | 405.8 | 0.65 |  |
|             |           | 0.6        | 2339.6 | 682.6  | 438.6 | 0.71 |  |
|             |           | 0.8        | 2140.5 | 748.8  | 478.2 | 0.78 |  |
|             | TAP 9     | 0.2        | 3427.5 | 681.0  | 663.9 | 1.12 |  |
|             |           | 0.4        | 3296.4 | 724.0  | 709.2 | 1.19 |  |
|             |           | 0.6        | 3167.9 | 766.5  | 744.1 | 1.26 |  |
|             |           | 0.8        | 3063.1 | 809.5  | 790.1 | 1.33 |  |
|             | TAP 10    | 0.2        | 3544.7 | 698.1  | 721.0 | 1.22 |  |
|             |           | 0.4        | 3417.5 | 739.5  | 767.6 | 1.29 |  |
|             |           | 0.6        | 3292.9 | 780.1  | 803.0 | 1.36 |  |
|             |           | 0.8        | 3196.9 | 820.6  | 849.6 | 1.44 |  |





# APPENDIX A BLOWER PERFORMANCE DATA

## 7.5 TON GE

7.5T 225K 7 burner Standard Static

Motor 2.4 HP

Model: DSG090\_STD

### DOWNSHOT

### HORIZONTAL

|             |        | DOWNSHOT  |        |       |        |       |     |
|-------------|--------|-----------|--------|-------|--------|-------|-----|
|             |        | TAP SPEED | ESP    | SCFM  | R.P.M. | WATTS | BHP |
| PL Rated    | TAP 1  | 0.2       | 1929.7 | 536.8 | 419.1  | 0.31  |     |
|             |        | 0.4       | 1730.8 | 593.8 | 459.0  | 0.35  |     |
|             |        | 0.6       | 1550.9 | 667.4 | 505.7  | 0.39  |     |
|             |        | 0.8       |        |       |        |       |     |
| PL Max CFM  | TAP 2  | 0.2       | 2136.3 | 560.5 | 505.7  | 0.40  |     |
|             |        | 0.4       | 1958.0 | 620.0 | 548.5  | 0.45  |     |
|             |        | 0.6       | 1791.2 | 690.0 | 597.1  | 0.50  |     |
|             |        | 0.8       | 1671.5 | 750.9 | 637.5  | 0.54  |     |
| Rated       | TAP 3  | 0.2       | 3009.4 | 703.2 | 971.3  | 0.94  |     |
|             |        | 0.4       | 2903.6 | 738.2 | 1026.8 | 0.98  |     |
|             |        | 0.6       | 2785.5 | 792.3 | 1084.2 | 1.05  |     |
|             |        | 0.8       | 2650.1 | 838.3 | 1141.3 | 1.12  |     |
| 400 CFM/Ton | TAP 4  | 0.2       | 3208.2 | 735.7 | 1108.4 | 1.10  |     |
|             |        | 0.4       | 3114.3 | 767.3 | 1166.9 | 1.15  |     |
|             |        | 0.6       | 3005.3 | 817.9 | 1226.4 | 1.22  |     |
|             |        | 0.8       | 2870.3 | 860.7 | 1286.8 | 1.28  |     |
| 400 CFM/Ton | TAP 5  | 0.2       | 3329.8 | 755.5 | 1200.3 | 1.21  |     |
|             |        | 0.4       | 3242.0 | 785.7 | 1260.6 | 1.25  |     |
|             |        | 0.6       | 3138.1 | 834.1 | 1321.5 | 1.33  |     |
|             |        | 0.8       | 3004.5 | 875.2 | 1383.8 | 1.40  |     |
|             | TAP 6  | 0.2       | 2476.2 | 616.1 | 665.3  | 0.58  |     |
|             |        | 0.4       | 2329.3 | 664.5 | 713.0  | 0.63  |     |
|             |        | 0.6       | 2182.9 | 728.3 | 765.0  | 0.69  |     |
|             |        | 0.8       | 2054.2 | 783.1 | 812.2  | 0.74  |     |
|             | TAP 7  | 0.2       | 3174.1 | 730.1 | 1083.7 | 0.69  |     |
|             |        | 0.4       | 3078.2 | 762.3 | 1141.7 | 0.72  |     |
|             |        | 0.6       | 2967.8 | 813.4 | 1200.9 | 0.77  |     |
|             |        | 0.8       | 2832.6 | 856.8 | 1260.7 | 0.81  |     |
|             | TAP 8  | 0.2       | 3735.1 | 821.6 | 1564.9 | 1.63  |     |
|             |        | 0.4       | 3659.0 | 851.3 | 1631.5 | 1.69  |     |
|             |        | 0.6       | 3568.1 | 892.2 | 1697.1 | 1.77  |     |
|             |        | 0.8       | 3446.6 | 928.0 | 1764.8 | 1.84  |     |
|             | TAP 9  | 0.2       | 3208.2 | 735.7 | 1108.4 | 1.10  |     |
|             |        | 0.4       | 3114.3 | 767.3 | 1166.9 | 1.15  |     |
|             |        | 0.6       | 3005.3 | 817.9 | 1226.4 | 1.22  |     |
|             |        | 0.8       | 2870.3 | 860.7 | 1286.8 | 1.28  |     |
|             | TAP 10 | 0.2       | 3329.8 | 755.5 | 1200.3 | 1.21  |     |
|             |        | 0.4       | 3242.0 | 785.7 | 1260.6 | 1.25  |     |
|             |        | 0.6       | 3138.1 | 834.1 | 1321.5 | 1.33  |     |
|             |        | 0.8       | 3004.5 | 875.2 | 1383.8 | 1.40  |     |

|             |        | HORIZONTAL |        |       |        |       |     |
|-------------|--------|------------|--------|-------|--------|-------|-----|
|             |        | TAP SPEED  | ESP    | SCFM  | R.P.M. | WATTS | BHP |
| PL Rated    | TAP 1  | 0.2        | 1990.9 | 484.9 | 392.3  | 0.29  |     |
|             |        | 0.4        | 1790.9 | 571.8 | 440.7  | 0.34  |     |
|             |        | 0.6        | 1567.6 | 650.0 | 486.3  | 0.38  |     |
|             |        | 0.8        |        |       |        |       |     |
| PL Max CFM  | TAP 2  | 0.2        | 2210.0 | 514.7 | 472.7  | 0.37  |     |
|             |        | 0.4        | 2025.7 | 593.8 | 522.3  | 0.43  |     |
|             |        | 0.6        | 1821.2 | 667.0 | 570.7  | 0.48  |     |
|             |        | 0.8        | 1724.2 | 733.7 | 619.1  | 0.53  |     |
| Rated       | TAP 3  | 0.2        | 3130.2 | 642.9 | 903.6  | 0.86  |     |
|             |        | 0.4        | 3002.2 | 693.6 | 961.1  | 0.92  |     |
|             |        | 0.6        | 2865.4 | 748.0 | 1023.2 | 1.00  |     |
|             |        | 0.8        | 2742.5 | 797.5 | 1085.2 | 1.06  |     |
| 400 CFM/Ton | TAP 4  | 0.2        | 3337.8 | 672.8 | 1030.2 | 1.00  |     |
|             |        | 0.4        | 3219.5 | 718.4 | 1090.3 | 1.07  |     |
|             |        | 0.6        | 3094.5 | 769.2 | 1156.1 | 1.15  |     |
|             |        | 0.8        | 2970.0 | 815.2 | 1220.5 | 1.22  |     |
| 400 CFM/Ton | TAP 5  | 0.2        | 3464.4 | 691.3 | 1114.9 | 1.10  |     |
|             |        | 0.4        | 3351.3 | 734.2 | 1176.8 | 1.17  |     |
|             |        | 0.6        | 3232.5 | 782.9 | 1245.1 | 1.25  |     |
|             |        | 0.8        | 3108.2 | 826.8 | 1310.8 | 1.32  |     |
|             | TAP 6  | 0.2        | 2569.5 | 564.1 | 620.7  | 0.53  |     |
|             |        | 0.4        | 2409.3 | 631.1 | 672.8  | 0.59  |     |
|             |        | 0.6        | 2233.7 | 696.6 | 726.1  | 0.66  |     |
|             |        | 0.8        | 2123.6 | 756.3 | 780.3  | 0.71  |     |
|             | TAP 7  | 0.2        | 3302.2 | 667.7 | 1007.4 | 0.63  |     |
|             |        | 0.4        | 3182.4 | 714.1 | 1067.1 | 0.67  |     |
|             |        | 0.6        | 3055.5 | 765.5 | 1132.2 | 0.72  |     |
|             |        | 0.8        | 2931.1 | 812.1 | 1196.2 | 0.77  |     |
|             | TAP 8  | 0.2        | 3882.5 | 754.3 | 1450.6 | 1.50  |     |
|             |        | 0.4        | 3780.8 | 790.7 | 1520.1 | 1.57  |     |
|             |        | 0.6        | 3676.0 | 833.8 | 1597.8 | 1.66  |     |
|             |        | 0.8        | 3562.0 | 871.6 | 1666.5 | 1.73  |     |
|             | TAP 9  | 0.2        | 3337.8 | 672.8 | 1030.2 | 1.00  |     |
|             |        | 0.4        | 3219.5 | 718.4 | 1090.3 | 1.07  |     |
|             |        | 0.6        | 3094.5 | 769.2 | 1156.1 | 1.15  |     |
|             |        | 0.8        | 2970.0 | 815.2 | 1220.5 | 1.22  |     |
|             | TAP 10 | 0.2        | 3464.4 | 691.3 | 1114.9 | 1.10  |     |
|             |        | 0.4        | 3351.3 | 734.2 | 1176.8 | 1.17  |     |
|             |        | 0.6        | 3232.5 | 782.9 | 1245.1 | 1.25  |     |
|             |        | 0.8        | 3108.2 | 826.8 | 1310.8 | 1.32  |     |







# APPENDIX A BLOWER PERFORMANCE DATA

## 8.5 TON GE

8.5T 130K 5 burner Standard Static

Motor 2.4 HP

Model: DSG102\_STD

### DOWNSHOT

### HORIZONTAL

|                       |           | DOWNSHOT |        |        |        |      |  |
|-----------------------|-----------|----------|--------|--------|--------|------|--|
|                       | TAP SPEED | ESP      | SCFM   | R.P.M. | WATTS  | BHP  |  |
| PL Rated              | TAP 1     | 0.2      | 2071.2 | 505.1  | 208.1  | 0.33 |  |
|                       |           | 0.4      | 1893.1 | 572.5  | 243.9  | 0.37 |  |
|                       |           | 0.6      | 1704.8 | 639.2  | 266.7  | 0.41 |  |
|                       |           | 0.8      |        |        |        |      |  |
| PL Max CFM            | TAP 2     | 0.2      | 2267.8 | 533.5  | 267.6  | 0.41 |  |
|                       |           | 0.4      | 2094.7 | 597.1  | 302.9  | 0.46 |  |
|                       |           | 0.6      | 1918.3 | 659.7  | 326.6  | 0.51 |  |
|                       |           | 0.8      | 1761.2 | 704.1  | 351.0  | 0.55 |  |
| Rated                 | TAP 3     | 0.2      | 3305.3 | 685.8  | 656.2  | 1.06 |  |
|                       |           | 0.4      | 3160.4 | 731.7  | 693.7  | 1.13 |  |
|                       |           | 0.6      | 3033.8 | 775.6  | 724.1  | 1.20 |  |
|                       |           | 0.8      | 2934.3 | 812.4  | 763.4  | 1.26 |  |
| 400 CFM/Ton @ 0.6 ESP | TAP 4     | 0.2      | 3652.3 | 738.1  | 828.1  | 1.37 |  |
|                       |           | 0.4      | 3518.0 | 779.6  | 869.0  | 1.45 |  |
|                       |           | 0.6      | 3400.6 | 818.9  | 902.6  | 1.53 |  |
|                       |           | 0.8      | 3309.5 | 854.6  | 949.7  | 1.59 |  |
| 400 CFM/Ton           | TAP 5     | 0.2      | 3739.7 | 751.5  | 876.4  | 1.46 |  |
|                       |           | 0.4      | 3608.2 | 792.1  | 918.5  | 1.54 |  |
|                       |           | 0.6      | 3492.1 | 830.4  | 953.0  | 1.62 |  |
|                       |           | 0.8      | 3401.8 | 865.9  | 1002.4 | 1.69 |  |
|                       | TAP 6     | 0.2      | 1859.9 | 474.6  | 147.9  | 0.24 |  |
|                       |           | 0.4      |        |        |        |      |  |
|                       |           | 0.6      |        |        |        |      |  |
|                       |           | 0.8      |        |        |        |      |  |
|                       | TAP 7     | 0.2      | 1974.0 | 491.0  | 180.0  | 0.25 |  |
|                       |           | 0.4      | 1793.5 | 560.5  | 216.1  | 0.29 |  |
|                       |           | 0.6      |        |        |        |      |  |
|                       |           | 0.8      |        |        |        |      |  |
|                       | TAP 8     | 0.2      | 2303.5 | 538.6  | 278.7  | 0.43 |  |
|                       |           | 0.4      | 2131.3 | 601.5  | 314.0  | 0.48 |  |
|                       |           | 0.6      | 1957.0 | 663.4  | 337.9  | 0.53 |  |
|                       |           | 0.8      | 1802.4 | 707.5  | 362.6  | 0.57 |  |
|                       | TAP 9     | 0.2      | 3652.3 | 738.1  | 828.1  | 1.37 |  |
|                       |           | 0.4      | 3518.0 | 779.6  | 869.0  | 1.45 |  |
|                       |           | 0.6      | 3400.6 | 818.9  | 902.6  | 1.53 |  |
|                       |           | 0.8      | 3309.5 | 854.6  | 949.7  | 1.59 |  |
|                       | TAP 10    | 0.2      | 3739.7 | 751.5  | 876.4  | 1.46 |  |
|                       |           | 0.4      | 3608.2 | 792.1  | 918.5  | 1.54 |  |
|                       |           | 0.6      | 3492.1 | 830.4  | 953.0  | 1.62 |  |
|                       |           | 0.8      | 3401.8 | 865.9  | 1002.4 | 1.69 |  |

|                       |           | HORIZONTAL |        |        |       |      |  |
|-----------------------|-----------|------------|--------|--------|-------|------|--|
|                       | TAP SPEED | ESP        | SCFM   | R.P.M. | WATTS | BHP  |  |
| PL Rated              | TAP 1     | 0.2        | 2062.9 | 495.5  | 222.9 | 0.32 |  |
|                       |           | 0.4        | 1894.9 | 561.5  | 248.8 | 0.36 |  |
|                       |           | 0.6        | 1700.1 | 628.3  | 280.7 | 0.41 |  |
|                       |           | 0.8        |        |        |       |      |  |
| PL Max CFM            | TAP 2     | 0.2        | 2262.4 | 523.3  | 274.2 | 0.41 |  |
|                       |           | 0.4        | 2099.4 | 585.8  | 301.2 | 0.45 |  |
|                       |           | 0.6        | 1916.9 | 648.9  | 335.2 | 0.50 |  |
|                       |           | 0.8        |        |        |       |      |  |
| Rated                 | TAP 3     | 0.2        | 3313.9 | 672.8  | 629.0 | 1.04 |  |
|                       |           | 0.4        | 3178.8 | 718.8  | 665.1 | 1.11 |  |
|                       |           | 0.6        | 3051.6 | 763.7  | 708.8 | 1.18 |  |
|                       |           | 0.8        | 2940.3 | 808.8  | 749.0 | 1.25 |  |
| 400 CFM/Ton @ 0.6 ESP | TAP 4     | 0.2        | 3664.9 | 724.5  | 794.9 | 1.35 |  |
|                       |           | 0.4        | 3540.0 | 765.7  | 835.6 | 1.43 |  |
|                       |           | 0.6        | 3426.1 | 805.8  | 881.9 | 1.50 |  |
|                       |           | 0.8        | 3339.9 | 844.0  | 924.3 | 1.57 |  |
| 400 CFM/Ton           | TAP 5     | 0.2        | 3753.2 | 737.7  | 842.4 | 1.44 |  |
|                       |           | 0.4        | 3630.9 | 777.7  | 884.4 | 1.52 |  |
|                       |           | 0.6        | 3519.7 | 816.9  | 931.3 | 1.59 |  |
|                       |           | 0.8        | 3437.3 | 853.7  | 974.3 | 1.66 |  |
|                       | TAP 6     | 0.2        | 1848.3 | 465.9  | 172.1 | 0.24 |  |
|                       |           | 0.4        |        |        |       |      |  |
|                       |           | 0.6        |        |        |       |      |  |
|                       |           | 0.8        |        |        |       |      |  |
|                       | TAP 7     | 0.2        | 1964.2 | 481.9  | 199.0 | 0.25 |  |
|                       |           | 0.4        | 1793.8 | 549.5  | 224.3 | 0.28 |  |
|                       |           | 0.6        |        |        |       |      |  |
|                       |           | 0.8        |        |        |       |      |  |
|                       | TAP 8     | 0.2        | 2298.6 | 528.4  | 283.9 | 0.42 |  |
|                       |           | 0.4        | 2136.5 | 590.3  | 311.2 | 0.47 |  |
|                       |           | 0.6        | 1956.2 | 652.6  | 345.5 | 0.52 |  |
|                       |           | 0.8        | 1713.2 | 726.5  | 379.4 | 0.58 |  |
|                       | TAP 9     | 0.2        | 3664.9 | 724.5  | 794.9 | 1.35 |  |
|                       |           | 0.4        | 3540.0 | 765.7  | 835.6 | 1.43 |  |
|                       |           | 0.6        | 3426.1 | 805.8  | 881.9 | 1.50 |  |
|                       |           | 0.8        | 3339.9 | 844.0  | 924.3 | 1.57 |  |
|                       | TAP 10    | 0.2        | 3753.2 | 737.7  | 842.4 | 1.44 |  |
|                       |           | 0.4        | 3630.9 | 777.7  | 884.4 | 1.52 |  |
|                       |           | 0.6        | 3519.7 | 816.9  | 931.3 | 1.59 |  |
|                       |           | 0.8        | 3437.3 | 853.7  | 974.3 | 1.66 |  |





# APPENDIX A BLOWER PERFORMANCE DATA

## 8.5 TON GE

8.5T 180K 6 burner Standard Static

Motor 2.4 HP

Model: DSG102\_STD

### DOWNSHOT

### HORIZONTAL

|                       |        | TAP SPEED | ESP    | SCFM  | R.P.M. | WATTS | BHP |
|-----------------------|--------|-----------|--------|-------|--------|-------|-----|
| PL Rated              | TAP 1  | 0.2       | 1996.1 | 520.4 | 235.8  | 0.34  |     |
|                       |        | 0.4       | 1915.5 | 556.0 | 247.5  | 0.37  |     |
|                       |        | 0.6       |        |       |        |       |     |
|                       |        | 0.8       |        |       |        |       |     |
| PL Max CFM            | TAP 2  | 0.2       | 2239.4 | 558.4 | 301.7  | 0.46  |     |
|                       |        | 0.4       | 2143.9 | 596.8 | 318.7  | 0.49  |     |
|                       |        | 0.6       | 1876.3 | 662.5 | 360.3  | 0.56  |     |
|                       |        | 0.8       |        |       |        |       |     |
| Rated                 | TAP 3  | 0.2       | 3256.8 | 716.6 | 681.2  | 1.16  |     |
|                       |        | 0.4       | 3121.6 | 760.8 | 716.9  | 1.23  |     |
|                       |        | 0.6       | 3014.4 | 796.2 | 747.6  | 1.29  |     |
|                       |        | 0.8       | 2882.8 | 841.8 | 795.5  | 1.36  |     |
| 400 CFM/Ton @ 0.6 ESP | TAP 4  | 0.2       | 3617.6 | 772.3 | 875.2  | 1.51  |     |
|                       |        | 0.4       | 3481.1 | 815.2 | 915.6  | 1.59  |     |
|                       |        | 0.6       | 3399.0 | 841.6 | 946.8  | 1.64  |     |
|                       |        | 0.8       | 3286.7 | 881.7 | 996.9  | 1.72  |     |
| 400 CFM/Ton           | TAP 5  | 0.2       | 3720.7 | 788.1 | 939.2  | 1.62  |     |
|                       |        | 0.4       | 3585.7 | 830.2 | 980.7  | 1.71  |     |
|                       |        | 0.6       | 3506.1 | 855.3 | 1012.7 | 1.76  |     |
|                       |        | 0.8       | 3397.9 | 894.0 | 1063.0 | 1.84  |     |
|                       | TAP 6  | 0.2       | 1705.3 | 474.8 | 166.4  | 0.22  |     |
|                       |        | 0.4       |        |       |        |       |     |
|                       |        | 0.6       |        |       |        |       |     |
|                       |        | 0.8       |        |       |        |       |     |
|                       | TAP 7  | 0.2       | 2136.4 | 542.3 | 272.9  | 0.25  |     |
|                       |        | 0.4       | 2047.0 | 579.6 | 287.7  | 0.27  |     |
|                       |        | 0.6       | 1758.1 | 671.8 | 331.1  | 0.31  |     |
|                       |        | 0.8       |        |       |        |       |     |
|                       | TAP 8  | 0.2       | 2536.8 | 604.8 | 393.3  | 0.63  |     |
|                       |        | 0.4       | 2425.6 | 646.0 | 416.5  | 0.67  |     |
|                       |        | 0.6       | 2215.3 | 714.1 | 453.4  | 0.74  |     |
|                       |        | 0.8       | 2027.6 | 772.9 | 492.1  | 0.80  |     |
|                       | TAP 9  | 0.2       | 3617.6 | 772.3 | 875.2  | 1.51  |     |
|                       |        | 0.4       | 3481.1 | 815.2 | 915.6  | 1.59  |     |
|                       |        | 0.6       | 3399.0 | 841.6 | 946.8  | 1.64  |     |
|                       |        | 0.8       | 3286.7 | 881.7 | 996.9  | 1.72  |     |
|                       | TAP 10 | 0.2       | 3720.7 | 788.1 | 939.2  | 1.62  |     |
|                       |        | 0.4       | 3585.7 | 830.2 | 980.7  | 1.71  |     |
|                       |        | 0.6       | 3506.1 | 855.3 | 1012.7 | 1.76  |     |
|                       |        | 0.8       | 3397.9 | 894.0 | 1063.0 | 1.84  |     |

|                       |        | TAP SPEED | ESP    | SCFM  | R.P.M. | WATTS | BHP |
|-----------------------|--------|-----------|--------|-------|--------|-------|-----|
| PL Rated              | TAP 1  | 0.2       | 2106.0 | 491.5 | 223.8  | 0.32  |     |
|                       |        | 0.4       | 1916.6 | 558.4 | 248.0  | 0.37  |     |
|                       |        | 0.6       | 1734.4 | 626.5 | 279.7  | 0.41  |     |
|                       |        | 0.8       |        |       |        |       |     |
| PL Max CFM            | TAP 2  | 0.2       | 2355.4 | 526.9 | 285.3  | 0.43  |     |
|                       |        | 0.4       | 2178.5 | 588.7 | 314.0  | 0.49  |     |
|                       |        | 0.6       | 2007.5 | 651.4 | 346.2  | 0.54  |     |
|                       |        | 0.8       | 1757.7 | 728.8 | 382.6  | 0.60  |     |
| Rated                 | TAP 3  | 0.2       | 3394.8 | 676.2 | 648.7  | 1.09  |     |
|                       |        | 0.4       | 3262.5 | 719.7 | 693.5  | 1.16  |     |
|                       |        | 0.6       | 3132.9 | 762.7 | 728.4  | 1.23  |     |
|                       |        | 0.8       | 3025.3 | 806.5 | 774.1  | 1.30  |     |
| 400 CFM/Ton @ 0.6 ESP | TAP 4  | 0.2       | 3761.2 | 730.0 | 838.4  | 1.43  |     |
|                       |        | 0.4       | 3640.4 | 768.6 | 887.2  | 1.50  |     |
|                       |        | 0.6       | 3522.5 | 806.2 | 923.4  | 1.57  |     |
|                       |        | 0.8       | 3437.5 | 842.7 | 970.9  | 1.65  |     |
| 400 CFM/Ton           | TAP 5  | 0.2       | 3865.6 | 745.5 | 901.4  | 1.53  |     |
|                       |        | 0.4       | 3747.4 | 782.9 | 951.1  | 1.61  |     |
|                       |        | 0.6       | 3632.5 | 819.2 | 987.8  | 1.69  |     |
|                       |        | 0.8       | 3549.9 | 854.3 | 1035.5 | 1.76  |     |
|                       | TAP 6  | 0.2       | 1807.5 | 449.4 | 159.9  | 0.21  |     |
|                       |        | 0.4       |        |       |        |       |     |
|                       |        | 0.6       |        |       |        |       |     |
|                       |        | 0.8       |        |       |        |       |     |
|                       | TAP 7  | 0.2       | 2249.8 | 511.9 | 258.3  | 0.24  |     |
|                       |        | 0.4       | 2067.7 | 575.8 | 285.1  | 0.27  |     |
|                       |        | 0.6       | 1892.1 | 640.8 | 317.1  | 0.30  |     |
|                       |        | 0.8       |        |       |        |       |     |
|                       | TAP 8  | 0.2       | 2660.0 | 570.3 | 371.8  | 0.59  |     |
|                       |        | 0.4       | 2497.6 | 626.2 | 405.8  | 0.65  |     |
|                       |        | 0.6       | 2339.6 | 682.6 | 438.6  | 0.71  |     |
|                       |        | 0.8       | 2140.5 | 748.8 | 478.2  | 0.78  |     |
|                       | TAP 9  | 0.2       | 3761.2 | 730.0 | 838.4  | 1.43  |     |
|                       |        | 0.4       | 3640.4 | 768.6 | 887.2  | 1.50  |     |
|                       |        | 0.6       | 3522.5 | 806.2 | 923.4  | 1.57  |     |
|                       |        | 0.8       | 3437.5 | 842.7 | 970.9  | 1.65  |     |
|                       | TAP 10 | 0.2       | 3865.6 | 745.5 | 901.4  | 1.53  |     |
|                       |        | 0.4       | 3747.4 | 782.9 | 951.1  | 1.61  |     |
|                       |        | 0.6       | 3632.5 | 819.2 | 987.8  | 1.69  |     |
|                       |        | 0.8       | 3549.9 | 854.3 | 1035.5 | 1.76  |     |





# APPENDIX A BLOWER PERFORMANCE DATA

## 8.5 TON GE

8.5T 225K 7 burner Standard Static

Motor 2.4 HP

Model: DSG102\_STD

### DOWNSHOT

### HORIZONTAL

|                       |           | DOWNSHOT |        |        |        |      |  |
|-----------------------|-----------|----------|--------|--------|--------|------|--|
|                       | TAP SPEED | ESP      | SCFM   | R.F.M. | WATTS  | BHP  |  |
| PL Rated              | TAP 1     | 0.2      | 2037.9 | 544.4  | 463.5  | 0.36 |  |
|                       |           | 0.4      | 1849.9 | 607.5  | 504.9  | 0.40 |  |
|                       |           | 0.6      |        |        |        |      |  |
|                       |           | 0.8      |        |        |        |      |  |
| PL Max CFM            | TAP 2     | 0.2      | 2291.2 | 585.9  | 575.6  | 0.48 |  |
|                       |           | 0.4      | 2127.7 | 640.1  | 620.6  | 0.52 |  |
|                       |           | 0.6      | 1970.3 | 707.2  | 670.8  | 0.58 |  |
|                       |           | 0.8      | 1846.2 | 765.3  | 714.3  | 0.63 |  |
| Rated                 | TAP 3     | 0.2      | 3351.4 | 759.1  | 1217.2 | 1.23 |  |
|                       |           | 0.4      | 3264.6 | 789.1  | 1277.9 | 1.28 |  |
|                       |           | 0.6      | 3161.5 | 837.0  | 1339.0 | 1.35 |  |
|                       |           | 0.8      | 3028.2 | 877.8  | 1401.6 | 1.42 |  |
| 400 CFM/Ton @ 0.6 ESP | TAP 4     | 0.2      | 3571.4 | 795.0  | 1405.0 | 1.45 |  |
|                       |           | 0.4      | 3492.5 | 823.9  | 1469.0 | 1.50 |  |
|                       |           | 0.6      | 3397.1 | 867.8  | 1532.7 | 1.58 |  |
|                       |           | 0.8      | 3269.0 | 905.6  | 1598.4 | 1.65 |  |
| 400 CFM/Ton           | TAP 5     | 0.2      | 3708.0 | 817.2  | 1537.0 | 1.60 |  |
|                       |           | 0.4      | 3631.7 | 846.7  | 1603.2 | 1.66 |  |
|                       |           | 0.6      | 3540.1 | 888.0  | 1668.5 | 1.74 |  |
|                       |           | 0.8      | 3417.3 | 924.2  | 1735.9 | 1.81 |  |
|                       | TAP 6     | 0.2      | 2476.2 | 616.1  | 665.3  | 0.58 |  |
|                       |           | 0.4      | 2329.3 | 664.5  | 713.0  | 0.63 |  |
|                       |           | 0.6      | 2182.9 | 728.3  | 765.0  | 0.69 |  |
|                       |           | 0.8      | 2054.2 | 783.1  | 812.2  | 0.74 |  |
|                       | TAP 7     | 0.2      | 3174.1 | 730.1  | 1083.7 | 0.69 |  |
|                       |           | 0.4      | 3078.2 | 762.3  | 1141.7 | 0.72 |  |
|                       |           | 0.6      | 2967.8 | 813.4  | 1200.9 | 0.77 |  |
|                       |           | 0.8      | 2832.6 | 856.8  | 1260.7 | 0.81 |  |
|                       | TAP 8     | 0.2      | 3735.1 | 821.6  | 1564.9 | 1.63 |  |
|                       |           | 0.4      | 3659.0 | 851.3  | 1631.5 | 1.69 |  |
|                       |           | 0.6      | 3568.1 | 892.2  | 1697.1 | 1.77 |  |
|                       |           | 0.8      | 3446.6 | 928.0  | 1764.8 | 1.84 |  |
|                       | TAP 9     | 0.2      | 3571.4 | 795.0  | 1405.0 | 1.45 |  |
|                       |           | 0.4      | 3492.5 | 823.9  | 1469.0 | 1.50 |  |
|                       |           | 0.6      | 3397.1 | 867.8  | 1532.7 | 1.58 |  |
|                       |           | 0.8      | 3269.0 | 905.6  | 1598.4 | 1.65 |  |
|                       | TAP 10    | 0.2      | 3708.0 | 817.2  | 1537.0 | 1.60 |  |
|                       |           | 0.4      | 3631.7 | 846.7  | 1603.2 | 1.66 |  |
|                       |           | 0.6      | 3540.1 | 888.0  | 1668.5 | 1.74 |  |
|                       |           | 0.8      | 3417.3 | 924.2  | 1735.9 | 1.81 |  |

|                       |           | HORIZONTAL |        |        |        |      |  |
|-----------------------|-----------|------------|--------|--------|--------|------|--|
|                       | TAP SPEED | ESP        | SCFM   | R.F.M. | WATTS  | BHP  |  |
| PL Rated              | TAP 1     | 0.2        | 2105.6 | 500.5  | 433.5  | 0.33 |  |
|                       |           | 0.4        | 1914.0 | 583.3  | 482.6  | 0.38 |  |
|                       |           | 0.6        | 1700.6 | 658.8  | 529.6  | 0.43 |  |
|                       |           | 0.8        |        |        |        |      |  |
| PL Max CFM            | TAP 2     | 0.2        | 2374.1 | 537.1  | 537.5  | 0.44 |  |
|                       |           | 0.4        | 2201.0 | 610.6  | 588.2  | 0.50 |  |
|                       |           | 0.6        | 2010.1 | 680.3  | 638.8  | 0.56 |  |
|                       |           | 0.8        | 1906.7 | 743.7  | 689.9  | 0.61 |  |
| Rated                 | TAP 3     | 0.2        | 3486.8 | 694.6  | 1130.5 | 1.12 |  |
|                       |           | 0.4        | 3374.5 | 737.0  | 1192.8 | 1.19 |  |
|                       |           | 0.6        | 3256.8 | 785.4  | 1261.5 | 1.27 |  |
|                       |           | 0.8        | 3132.5 | 829.0  | 1327.4 | 1.34 |  |
| 400 CFM/Ton @ 0.6 ESP | TAP 4     | 0.2        | 3714.4 | 728.6  | 1303.5 | 1.33 |  |
|                       |           | 0.4        | 3609.3 | 767.0  | 1369.6 | 1.40 |  |
|                       |           | 0.6        | 3500.4 | 812.1  | 1443.2 | 1.48 |  |
|                       |           | 0.8        | 3379.4 | 852.2  | 1511.0 | 1.55 |  |
| 400 CFM/Ton           | TAP 5     | 0.2        | 3854.7 | 750.0  | 1425.0 | 1.47 |  |
|                       |           | 0.4        | 3752.6 | 786.7  | 1493.9 | 1.54 |  |
|                       |           | 0.6        | 3647.4 | 830.1  | 1570.8 | 1.63 |  |
|                       |           | 0.8        | 3530.5 | 868.2  | 1639.4 | 1.70 |  |
|                       | TAP 6     | 0.2        | 2569.5 | 564.1  | 620.7  | 0.53 |  |
|                       |           | 0.4        | 2409.3 | 631.1  | 672.8  | 0.59 |  |
|                       |           | 0.6        | 2233.7 | 696.6  | 726.1  | 0.66 |  |
|                       |           | 0.8        | 2123.6 | 756.3  | 780.3  | 0.71 |  |
|                       | TAP 7     | 0.2        | 3302.2 | 667.7  | 1007.4 | 0.63 |  |
|                       |           | 0.4        | 3182.4 | 714.1  | 1067.1 | 0.67 |  |
|                       |           | 0.6        | 3055.5 | 765.5  | 1132.2 | 0.72 |  |
|                       |           | 0.8        | 2931.1 | 812.1  | 1196.2 | 0.77 |  |
|                       | TAP 8     | 0.2        | 3882.5 | 754.3  | 1450.6 | 1.50 |  |
|                       |           | 0.4        | 3780.8 | 790.7  | 1520.1 | 1.57 |  |
|                       |           | 0.6        | 3676.0 | 833.8  | 1597.8 | 1.66 |  |
|                       |           | 0.8        | 3560.2 | 871.6  | 1666.5 | 1.73 |  |
|                       | TAP 9     | 0.2        | 3714.4 | 728.6  | 1303.5 | 1.33 |  |
|                       |           | 0.4        | 3609.3 | 767.0  | 1369.6 | 1.40 |  |
|                       |           | 0.6        | 3500.4 | 812.1  | 1443.2 | 1.48 |  |
|                       |           | 0.8        | 3379.4 | 852.2  | 1511.0 | 1.55 |  |
|                       | TAP 10    | 0.2        | 3854.7 | 750.0  | 1425.0 | 1.47 |  |
|                       |           | 0.4        | 3752.6 | 786.7  | 1493.9 | 1.54 |  |
|                       |           | 0.6        | 3647.4 | 830.1  | 1570.8 | 1.63 |  |
|                       |           | 0.8        | 3530.5 | 868.2  | 1639.4 | 1.70 |  |







# APPENDIX A BLOWER PERFORMANCE DATA

## 10 TON GE

10T 130K 5 burner Standard Static

Motor 3.5 HP

Model: DSG120\_STD

### DOWNSHOT

### HORIZONTAL

|                       |           | DOWNSHOT |        |        |        |      |  |
|-----------------------|-----------|----------|--------|--------|--------|------|--|
|                       | TAP SPEED | ESP      | SCFM   | R.F.M. | WATTS  | BHP  |  |
| PL Rated              | TAP 1     | 0.2      | 2115.6 | 500.0  | 227.8  | 0.35 |  |
|                       |           | 0.4      |        |        |        |      |  |
|                       |           | 0.6      |        |        |        |      |  |
|                       |           | 0.8      |        |        |        |      |  |
| PL Max CFM            | TAP 2     | 0.2      | 2346.3 | 530.3  | 284.9  | 0.45 |  |
|                       |           | 0.4      | 2091.2 | 603.9  | 323.6  | 0.51 |  |
|                       |           | 0.6      |        |        |        |      |  |
|                       |           | 0.8      |        |        |        |      |  |
| Rated                 | TAP 3     | 0.2      | 3452.3 | 679.4  | 668.5  | 1.14 |  |
|                       |           | 0.4      | 3328.6 | 722.4  | 719.8  | 1.21 |  |
|                       |           | 0.6      | 3173.6 | 773.3  | 757.2  | 1.29 |  |
|                       |           | 0.8      | 2957.6 | 834.9  | 804.4  | 1.39 |  |
| 400 CFM/Ton @ 0.6 ESP | TAP 4     | 0.2      | 4227.6 | 791.1  | 1139.6 | 1.95 |  |
|                       |           | 0.4      | 4117.5 | 827.9  | 1195.4 | 2.04 |  |
|                       |           | 0.6      | 4003.0 | 867.5  | 1244.8 | 2.13 |  |
|                       |           | 0.8      | 3861.3 | 910.4  | 1295.3 | 2.24 |  |
| 400 CFM/Ton           | TAP 5     | 0.2      | 4353.1 | 810.3  | 1249.2 | 2.12 |  |
|                       |           | 0.4      | 4232.3 | 848.7  | 1305.1 | 2.23 |  |
|                       |           | 0.6      | 4117.9 | 886.7  | 1357.4 | 2.33 |  |
|                       |           | 0.8      | 3999.7 | 923.4  | 1407.2 | 2.42 |  |
|                       | TAP 6     | 0.2      | 2115.6 | 500.0  | 227.8  | 0.35 |  |
|                       |           | 0.4      |        |        |        |      |  |
|                       |           | 0.6      |        |        |        |      |  |
|                       |           | 0.8      |        |        |        |      |  |
|                       | TAP 7     | 0.2      | 2188.7 | 509.6  | 245.2  | 0.35 |  |
|                       |           | 0.4      |        |        |        |      |  |
|                       |           | 0.6      |        |        |        |      |  |
|                       |           | 0.8      |        |        |        |      |  |
|                       | TAP 8     | 0.2      | 2261.0 | 519.0  | 263.0  | 0.41 |  |
|                       |           | 0.4      |        |        |        |      |  |
|                       |           | 0.6      |        |        |        |      |  |
|                       |           | 0.8      |        |        |        |      |  |
|                       | TAP 9     | 0.2      | 4227.6 | 791.1  | 1139.6 | 1.95 |  |
|                       |           | 0.4      | 4117.5 | 827.9  | 1195.4 | 2.04 |  |
|                       |           | 0.6      | 4003.0 | 867.5  | 1244.8 | 2.13 |  |
|                       |           | 0.8      | 3861.3 | 910.4  | 1295.3 | 2.24 |  |
|                       | TAP 10    | 0.2      | 4353.1 | 810.3  | 1249.2 | 2.12 |  |
|                       |           | 0.4      | 4232.3 | 848.7  | 1305.1 | 2.23 |  |
|                       |           | 0.6      | 4117.9 | 886.7  | 1357.4 | 2.33 |  |
|                       |           | 0.8      | 3999.7 | 923.4  | 1407.2 | 2.42 |  |

|                       |           | HORIZONTAL |        |        |        |      |  |
|-----------------------|-----------|------------|--------|--------|--------|------|--|
|                       | TAP SPEED | ESP        | SCFM   | R.F.M. | WATTS  | BHP  |  |
| PL Rated              | TAP 1     | 0.2        | 2044.3 | 494.2  | 367.1  | 0.34 |  |
|                       |           | 0.4        |        |        |        |      |  |
|                       |           | 0.6        |        |        |        |      |  |
|                       |           | 0.8        |        |        |        |      |  |
| PL Max CFM            | TAP 2     | 0.2        | 2325.5 | 518.8  | 452.6  | 0.44 |  |
|                       |           | 0.4        | 2145.8 | 579.7  | 495.6  | 0.49 |  |
|                       |           | 0.6        |        |        |        |      |  |
|                       |           | 0.8        |        |        |        |      |  |
| Rated                 | TAP 3     | 0.2        | 3601.5 | 645.8  | 1015.9 | 1.08 |  |
|                       |           | 0.4        | 3490.8 | 687.7  | 1077.6 | 1.15 |  |
|                       |           | 0.6        | 3347.8 | 738.6  | 1144.6 | 1.23 |  |
|                       |           | 0.8        | 3122.1 | 794.6  | 1222.3 | 1.33 |  |
| 400 CFM/Ton @ 0.6 ESP | TAP 4     | 0.2        | 4363.5 | 750.9  | 1692.9 | 1.85 |  |
|                       |           | 0.4        | 4266.5 | 789.2  | 1779.3 | 1.94 |  |
|                       |           | 0.6        | 4164.7 | 827.4  | 1860.0 | 2.04 |  |
|                       |           | 0.8        | 4033.6 | 867.9  | 1944.5 | 2.13 |  |
| 400 CFM/Ton           | TAP 5     | 0.2        | 4465.1 | 770.6  | 1849.1 | 2.02 |  |
|                       |           | 0.4        | 4364.5 | 809.9  | 1941.5 | 2.12 |  |
|                       |           | 0.6        | 4261.7 | 846.7  | 2025.2 | 2.22 |  |
|                       |           | 0.8        | 4158.2 | 887.2  | 2113.3 | 2.33 |  |
|                       | TAP 6     | 0.2        | 2044.3 | 494.2  | 367.1  | 0.34 |  |
|                       |           | 0.4        |        |        |        |      |  |
|                       |           | 0.6        |        |        |        |      |  |
|                       |           | 0.8        |        |        |        |      |  |
|                       | TAP 7     | 0.2        | 2133.9 | 502.0  | 393.3  | 0.35 |  |
|                       |           | 0.4        |        |        |        |      |  |
|                       |           | 0.6        |        |        |        |      |  |
|                       |           | 0.8        |        |        |        |      |  |
|                       | TAP 8     | 0.2        | 2221.9 | 509.7  | 420.0  | 0.40 |  |
|                       |           | 0.4        | 2035.5 | 572.3  | 462.0  | 0.45 |  |
|                       |           | 0.6        |        |        |        |      |  |
|                       |           | 0.8        |        |        |        |      |  |
|                       | TAP 9     | 0.2        | 4363.5 | 750.9  | 1692.9 | 1.85 |  |
|                       |           | 0.4        | 4266.5 | 789.2  | 1779.3 | 1.94 |  |
|                       |           | 0.6        | 4164.7 | 827.4  | 1860.0 | 2.04 |  |
|                       |           | 0.8        | 4033.6 | 867.9  | 1944.5 | 2.13 |  |
|                       | TAP 10    | 0.2        | 4465.1 | 770.6  | 1849.1 | 2.02 |  |
|                       |           | 0.4        | 4364.5 | 809.9  | 1941.5 | 2.12 |  |
|                       |           | 0.6        | 4261.7 | 846.7  | 2025.2 | 2.22 |  |
|                       |           | 0.8        | 4158.2 | 887.2  | 2113.3 | 2.33 |  |





# APPENDIX A BLOWER PERFORMANCE DATA

## 10 TON GE

10T 180K 6 burner Standard Static

Motor 3.5 HP

Model: DSG120\_STD

### DOWNSHOT

### HORIZONTAL

|                       |        | DOWNSHOT  |        |       |        |       |     |
|-----------------------|--------|-----------|--------|-------|--------|-------|-----|
|                       |        | TAP SPEED | ESP    | SCFM  | R.P.M. | WATTS | BHP |
| PL Rated              | TAP 1  | 0.2       | 2163.8 | 528.9 | 460.1  | 0.37  |     |
|                       |        | 0.4       |        |       |        |       |     |
|                       |        | 0.6       |        |       |        |       |     |
|                       |        | 0.8       |        |       |        |       |     |
| PL Max CFM            | TAP 2  | 0.2       | 2409.6 | 560.9 | 551.4  | 0.47  |     |
|                       |        | 0.4       | 2232.9 | 621.9 | 593.2  | 0.52  |     |
|                       |        | 0.6       | 2073.3 | 669.0 | 628.4  | 0.56  |     |
|                       |        | 0.8       |        |       |        |       |     |
| Rated                 | TAP 3  | 0.2       | 3405.6 | 693.5 | 1034.7 | 1.03  |     |
|                       |        | 0.4       | 3306.8 | 736.4 | 1088.3 | 1.09  |     |
|                       |        | 0.6       | 3211.4 | 778.5 | 1146.1 | 1.16  |     |
|                       |        | 0.8       | 2986.8 | 838.0 | 1211.8 | 1.24  |     |
| 400 CFM/Ton @ 0.6 ESP | TAP 4  | 0.2       | 4183.5 | 802.7 | 1644.1 | 1.74  |     |
|                       |        | 0.4       | 4103.7 | 840.7 | 1720.6 | 1.82  |     |
|                       |        | 0.6       | 4000.0 | 883.3 | 1800.1 | 1.91  |     |
|                       |        | 0.8       | 3873.5 | 923.0 | 1865.1 | 2.00  |     |
| 400 CFM/Ton           | TAP 5  | 0.2       | 4304.6 | 820.7 | 1776.7 | 1.89  |     |
|                       |        | 0.4       | 4220.9 | 859.3 | 1859.0 | 1.98  |     |
|                       |        | 0.6       | 4106.4 | 902.7 | 1942.5 | 2.08  |     |
|                       |        | 0.8       | 4004.1 | 937.6 | 2006.0 | 2.16  |     |
|                       | TAP 6  | 0.2       | 2174.6 | 530.1 | 449.7  | 0.32  |     |
|                       |        | 0.4       | 1951.8 | 611.4 | 506.7  | 0.37  |     |
|                       |        | 0.6       | 1741.7 | 671.5 | 556.9  | 0.41  |     |
|                       |        | 0.8       |        |       |        |       |     |
|                       | TAP 7  | 0.2       | 2681.9 | 596.7 | 663.3  | 0.36  |     |
|                       |        | 0.4       | 2530.2 | 651.9 | 707.2  | 0.39  |     |
|                       |        | 0.6       | 2393.2 | 697.2 | 748.2  | 0.42  |     |
|                       |        | 0.8       | 2123.7 | 766.4 | 807.5  | 0.46  |     |
|                       | TAP 8  | 0.2       | 3278.5 | 676.2 | 959.8  | 0.94  |     |
|                       |        | 0.4       | 3172.2 | 721.0 | 1011.2 | 1.00  |     |
|                       |        | 0.6       | 3071.9 | 763.4 | 1065.9 | 1.06  |     |
|                       |        | 0.8       | 2837.2 | 825.0 | 1130.8 | 1.15  |     |
|                       | TAP 9  | 0.2       | 4183.5 | 802.7 | 1644.1 | 1.74  |     |
|                       |        | 0.4       | 4103.7 | 840.7 | 1720.6 | 1.82  |     |
|                       |        | 0.6       | 4000.0 | 883.3 | 1800.1 | 1.91  |     |
|                       |        | 0.8       | 3873.5 | 923.0 | 1865.1 | 2.00  |     |
|                       | TAP 10 | 0.2       | 4304.6 | 820.7 | 1776.7 | 1.89  |     |
|                       |        | 0.4       | 4220.9 | 859.3 | 1859.0 | 1.98  |     |
|                       |        | 0.6       | 4106.4 | 902.7 | 1942.5 | 2.08  |     |
|                       |        | 0.8       | 4004.1 | 937.6 | 2006.0 | 2.16  |     |

|                       |        | HORIZONTAL |        |       |        |       |     |
|-----------------------|--------|------------|--------|-------|--------|-------|-----|
|                       |        | TAP SPEED  | ESP    | SCFM  | R.P.M. | WATTS | BHP |
| PL Rated              | TAP 1  | 0.2        | 2304.4 | 479.3 | 358.6  | 0.33  |     |
|                       |        | 0.4        | 2064.6 | 562.5 | 411.8  | 0.39  |     |
|                       |        | 0.6        |        |       |        |       |     |
|                       |        | 0.8        |        |       |        |       |     |
| PL Max CFM            | TAP 2  | 0.2        | 2548.5 | 505.6 | 437.4  | 0.42  |     |
|                       |        | 0.4        | 2342.6 | 582.3 | 494.4  | 0.49  |     |
|                       |        | 0.6        | 2161.7 | 642.7 | 539.6  | 0.54  |     |
|                       |        | 0.8        |        |       |        |       |     |
| Rated                 | TAP 3  | 0.2        | 3550.3 | 615.9 | 863.2  | 0.91  |     |
|                       |        | 0.4        | 3451.2 | 670.8 | 936.8  | 1.00  |     |
|                       |        | 0.6        | 3340.3 | 720.3 | 998.9  | 1.07  |     |
|                       |        | 0.8        | 3151.8 | 793.6 | 1085.7 | 1.18  |     |
| 400 CFM/Ton @ 0.6 ESP | TAP 4  | 0.2        | 4358.6 | 709.6 | 1413.5 | 1.54  |     |
|                       |        | 0.4        | 4280.9 | 756.3 | 1501.7 | 1.64  |     |
|                       |        | 0.6        | 4202.5 | 799.1 | 1583.3 | 1.73  |     |
|                       |        | 0.8        | 4079.2 | 855.6 | 1676.6 | 1.85  |     |
| 400 CFM/Ton           | TAP 5  | 0.2        | 4488.6 | 725.4 | 1534.5 | 1.67  |     |
|                       |        | 0.4        | 4404.2 | 772.3 | 1625.3 | 1.78  |     |
|                       |        | 0.6        | 4327.2 | 814.4 | 1710.9 | 1.87  |     |
|                       |        | 0.8        | 4216.2 | 865.8 | 1803.1 | 1.99  |     |
|                       | TAP 6  | 0.2        | 2135.8 | 461.3 | 308.5  | 0.28  |     |
|                       |        | 0.4        |        |       |        |       |     |
|                       |        | 0.6        |        |       |        |       |     |
|                       |        | 0.8        |        |       |        |       |     |
|                       | TAP 7  | 0.2        | 2820.2 | 535.1 | 534.9  | 0.37  |     |
|                       |        | 0.4        | 2648.8 | 605.1 | 596.3  | 0.37  |     |
|                       |        | 0.6        | 2489.1 | 662.3 | 645.5  | 0.40  |     |
|                       |        | 0.8        | 2251.5 | 738.7 | 715.3  | 0.45  |     |
|                       | TAP 8  | 0.2        | 3421.1 | 601.4 | 796.5  | 0.84  |     |
|                       |        | 0.4        | 3311.8 | 658.6 | 867.9  | 0.92  |     |
|                       |        | 0.6        | 3193.2 | 709.4 | 927.5  | 0.99  |     |
|                       |        | 0.8        | 2995.6 | 783.9 | 1011.8 | 1.09  |     |
|                       | TAP 9  | 0.2        | 4358.6 | 709.6 | 1413.5 | 1.54  |     |
|                       |        | 0.4        | 4280.9 | 756.3 | 1501.7 | 1.64  |     |
|                       |        | 0.6        | 4202.5 | 799.1 | 1583.3 | 1.73  |     |
|                       |        | 0.8        | 4079.2 | 855.6 | 1676.6 | 1.85  |     |
|                       | TAP 10 | 0.2        | 4488.6 | 725.4 | 1534.5 | 1.67  |     |
|                       |        | 0.4        | 4404.2 | 772.3 | 1625.3 | 1.78  |     |
|                       |        | 0.6        | 4327.2 | 814.4 | 1710.9 | 1.87  |     |
|                       |        | 0.8        | 4216.2 | 865.8 | 1803.1 | 1.99  |     |







# APPENDIX A BLOWER PERFORMANCE DATA

## 10 TON GE

10T 240K 7 burner Standard Static

Motor 3.5 HP

Model: DSG120\_STD

### DOWNSHOT

### HORIZONTAL

|                       |           | DOWNSHOT |        |        |        |      |  |
|-----------------------|-----------|----------|--------|--------|--------|------|--|
|                       | TAP SPEED | ESP      | SCFM   | R.F.M. | WATTS  | BHP  |  |
| PL Rated              | TAP 1     | 0.2      | 2168.6 | 554.6  | 276.5  | 0.43 |  |
|                       |           | 0.4      |        |        |        |      |  |
|                       |           | 0.6      |        |        |        |      |  |
|                       |           | 0.8      |        |        |        |      |  |
| PL Max CFM            | TAP 2     | 0.2      | 2449.9 | 600.3  | 363.5  | 0.58 |  |
|                       |           | 0.4      | 2202.5 | 671.5  | 399.0  | 0.65 |  |
|                       |           | 0.6      | 2030.8 | 720.7  | 431.6  | 0.70 |  |
|                       |           | 0.8      |        |        |        |      |  |
| Rated                 | TAP 3     | 0.2      | 3421.4 | 761.1  | 785.6  | 1.34 |  |
|                       |           | 0.4      | 3321.3 | 796.7  | 818.7  | 1.40 |  |
|                       |           | 0.6      | 3197.2 | 841.1  | 866.9  | 1.48 |  |
|                       |           | 0.8      | 3004.0 | 895.7  | 922.1  | 1.57 |  |
| 400 CFM/Ton @ 0.6 ESP | TAP 4     | 0.2      | 4193.3 | 895.3  | 1393.5 | 2.36 |  |
|                       |           | 0.4      | 4098.6 | 929.7  | 1434.6 | 2.46 |  |
|                       |           | 0.6      | 4002.7 | 961.5  | 1480.4 | 2.54 |  |
|                       |           | 0.8      | 3908.2 | 994.4  | 1529.9 | 2.63 |  |
| 400 CFM/Ton           | TAP 5     | 0.2      | 4286.7 | 912.5  | 1505.5 | 2.54 |  |
|                       |           | 0.4      | 4176.9 | 950.5  | 1549.0 | 2.65 |  |
|                       |           | 0.6      | 4083.0 | 979.6  | 1592.3 | 2.73 |  |
|                       |           | 0.8      | 4011.6 | 1007.0 | 1637.8 | 2.80 |  |
|                       | TAP 6     | 0.2      | 2462.9 | 602.4  | 367.8  | 0.59 |  |
|                       |           | 0.4      | 2218.0 | 673.0  | 403.3  | 0.66 |  |
|                       |           | 0.6      | 2047.0 | 722.2  | 436.1  | 0.70 |  |
|                       |           | 0.8      |        |        |        |      |  |
|                       | TAP 7     | 0.2      | 3092.6 | 706.1  | 616.1  | 0.69 |  |
|                       |           | 0.4      | 2953.6 | 751.1  | 649.1  | 0.73 |  |
|                       |           | 0.6      | 2814.3 | 798.0  | 693.5  | 0.78 |  |
|                       |           | 0.8      | 2604.9 | 855.0  | 743.1  | 0.83 |  |
|                       | TAP 8     | 0.2      | 3620.2 | 794.8  | 907.1  | 1.55 |  |
|                       |           | 0.4      | 3535.7 | 826.7  | 941.0  | 1.61 |  |
|                       |           | 0.6      | 3420.2 | 869.0  | 990.6  | 1.69 |  |
|                       |           | 0.8      | 3242.3 | 920.6  | 1047.3 | 1.79 |  |
|                       | TAP 9     | 0.2      | 4193.3 | 895.3  | 1393.5 | 2.36 |  |
|                       |           | 0.4      | 4098.6 | 929.7  | 1434.6 | 2.46 |  |
|                       |           | 0.6      | 4002.7 | 961.5  | 1480.4 | 2.54 |  |
|                       |           | 0.8      | 3908.2 | 994.4  | 1529.9 | 2.63 |  |
|                       | TAP 10    | 0.2      | 4286.7 | 912.5  | 1505.5 | 2.54 |  |
|                       |           | 0.4      | 4176.9 | 950.5  | 1549.0 | 2.65 |  |
|                       |           | 0.6      | 4083.0 | 979.6  | 1592.3 | 2.73 |  |
|                       |           | 0.8      | 4011.6 | 1007.0 | 1637.8 | 2.80 |  |

|                       |           | HORIZONTAL |        |        |        |      |  |
|-----------------------|-----------|------------|--------|--------|--------|------|--|
|                       | TAP SPEED | ESP        | SCFM   | R.F.M. | WATTS  | BHP  |  |
| PL Rated              | TAP 1     | 0.2        | 2325.3 | 498.4  | 255.7  | 0.38 |  |
|                       |           | 0.4        | 2029.1 | 591.7  | 294.1  | 0.46 |  |
|                       |           | 0.6        |        |        |        |      |  |
|                       |           | 0.8        |        |        |        |      |  |
| PL Max CFM            | TAP 2     | 0.2        | 2622.5 | 535.6  | 331.8  | 0.52 |  |
|                       |           | 0.4        | 2379.2 | 615.3  | 372.7  | 0.59 |  |
|                       |           | 0.6        | 2137.7 | 686.8  | 420.9  | 0.66 |  |
|                       |           | 0.8        |        |        |        |      |  |
| Rated                 | TAP 3     | 0.2        | 3663.4 | 668.2  | 701.2  | 1.17 |  |
|                       |           | 0.4        | 3552.5 | 712.4  | 752.3  | 1.25 |  |
|                       |           | 0.6        | 3410.3 | 765.9  | 808.2  | 1.34 |  |
|                       |           | 0.8        | 3177.9 | 836.4  | 859.9  | 1.47 |  |
| 400 CFM/Ton @ 0.6 ESP | TAP 4     | 0.2        | 4522.9 | 782.9  | 1233.4 | 2.07 |  |
|                       |           | 0.4        | 4404.8 | 824.7  | 1296.8 | 2.18 |  |
|                       |           | 0.6        | 4291.4 | 863.2  | 1346.0 | 2.28 |  |
|                       |           | 0.8        | 4183.4 | 905.9  | 1412.5 | 2.39 |  |
| 400 CFM/Ton           | TAP 5     | 0.2        | 4631.4 | 798.1  | 1331.5 | 2.22 |  |
|                       |           | 0.4        | 4496.6 | 843.2  | 1396.9 | 2.35 |  |
|                       |           | 0.6        | 4379.7 | 879.9  | 1443.6 | 2.45 |  |
|                       |           | 0.8        | 4302.2 | 914.8  | 1511.8 | 2.55 |  |
|                       | TAP 6     | 0.2        | 2636.3 | 537.3  | 335.6  | 0.52 |  |
|                       |           | 0.4        | 2395.3 | 616.4  | 376.6  | 0.60 |  |
|                       |           | 0.6        | 2155.4 | 687.7  | 424.9  | 0.67 |  |
|                       |           | 0.8        |        |        |        |      |  |
|                       | TAP 7     | 0.2        | 3308.0 | 622.4  | 552.8  | 0.61 |  |
|                       |           | 0.4        | 3163.2 | 676.1  | 600.0  | 0.66 |  |
|                       |           | 0.6        | 2992.3 | 735.7  | 654.6  | 0.72 |  |
|                       |           | 0.8        | 2743.2 | 808.1  | 700.2  | 0.79 |  |
|                       | TAP 8     | 0.2        | 3880.6 | 696.5  | 807.6  | 1.36 |  |
|                       |           | 0.4        | 3782.2 | 736.8  | 861.3  | 1.44 |  |
|                       |           | 0.6        | 3653.8 | 786.5  | 917.1  | 1.53 |  |
|                       |           | 0.8        | 3439.3 | 853.8  | 972.7  | 1.66 |  |
|                       | TAP 9     | 0.2        | 4522.9 | 782.9  | 1233.4 | 2.07 |  |
|                       |           | 0.4        | 4404.8 | 824.7  | 1296.8 | 2.18 |  |
|                       |           | 0.6        | 4291.4 | 863.2  | 1346.0 | 2.28 |  |
|                       |           | 0.8        | 4183.4 | 905.9  | 1412.5 | 2.39 |  |
|                       | TAP 10    | 0.2        | 4631.4 | 798.1  | 1331.5 | 2.22 |  |
|                       |           | 0.4        | 4496.6 | 843.2  | 1396.9 | 2.35 |  |
|                       |           | 0.6        | 4379.7 | 879.9  | 1443.6 | 2.45 |  |
|                       |           | 0.8        | 4302.2 | 914.8  | 1511.8 | 2.55 |  |

# APPENDIX A BLOWER PERFORMANCE DATA

## 10 TON GE

10T 240K 7 burner Medium Static

Motor 3.5 HP

Model: DSG120\_MED

### DOWNSHOT

### HORIZONTAL

|                 |           | DOWNSHOT |        |        |        |       |       |
|-----------------|-----------|----------|--------|--------|--------|-------|-------|
|                 | TAP SPEED | ESP      | SCFM   | R.F.M. | WATTS  | BHP   |       |
|                 |           | PL Rated | TAP 1  | 0.2    | 2435.1 | 597.2 | 365.7 |
| 0.4             | 2204.6    |          |        | 670.2  | 411.4  | 0.63  |       |
| 0.6             |           |          |        |        |        |       |       |
| 0.8             |           |          |        |        |        |       |       |
| 1               |           |          |        |        |        |       |       |
| 1.2             |           |          |        |        |        |       |       |
| 1.4             |           |          |        |        |        |       |       |
| PL CFM Max      | TAP 2     | 0.2      | 2697.4 | 639.9  | 483.9  | 0.71  |       |
|                 |           | 0.4      | 2491.1 | 705.5  | 528.0  | 0.78  |       |
|                 |           | 0.6      | 2279.5 | 759.8  | 564.4  | 0.84  |       |
|                 |           | 0.8      | 2125.2 | 805.3  | 593.4  | 0.89  |       |
|                 |           | 1        |        |        |        |       |       |
|                 |           | 1.2      |        |        |        |       |       |
|                 |           | 1.4      |        |        |        |       |       |
| Rated @ 0.8 ESP | TAP 3     | 0.2      | 3443.5 | 762.3  | 868.8  | 1.25  |       |
|                 |           | 0.4      | 3299.1 | 808.4  | 910.0  | 1.32  |       |
|                 |           | 0.6      | 3141.2 | 851.7  | 947.0  | 1.39  |       |
|                 |           | 0.8      | 3002.2 | 892.1  | 987.0  | 1.46  |       |
|                 |           | 1        | 2824.8 | 939.2  | 1045.1 | 1.53  |       |
|                 |           | 1.2      | 2617.2 | 991.1  | 1099.4 | 1.62  |       |
|                 |           | 1.4      | 2459.0 | 1028.5 | 1142.0 | 1.68  |       |
| 400 CFM/Ton     | TAP 4     | 0.2      | 4573.3 | 951.0  | 1681.3 | 2.52  |       |
|                 |           | 0.4      | 4489.6 | 976.3  | 1725.2 | 2.59  |       |
|                 |           | 0.6      | 4395.4 | 1006.4 | 1769.9 | 2.67  |       |
|                 |           | 0.8      | 4283.9 | 1038.6 | 1824.2 | 2.76  |       |
|                 |           | 1        | 4157.3 | 1075.2 | 1888.2 | 2.85  |       |
|                 |           | 1.2      | 4011.3 | 1118.0 | 1955.2 | 2.97  |       |
|                 |           | 1.4      | 3881.0 | 1151.1 | 1997.7 | 3.05  |       |
| 400 CFM/Ton     | TAP 5     | 0.2      | 4708.0 | 974.0  | 1811.7 | 2.73  |       |
|                 |           | 0.4      | 4626.7 | 998.1  | 1856.9 | 2.80  |       |
|                 |           | 0.6      | 4537.5 | 1027.1 | 1903.5 | 2.88  |       |
|                 |           | 0.8      | 4429.9 | 1058.2 | 1959.1 | 2.97  |       |
|                 |           | 1        | 4310.9 | 1092.9 | 2021.6 | 3.07  |       |
|                 |           | 1.2      | 4174.4 | 1133.5 | 2088.9 | 3.18  |       |
|                 |           | 1.4      | 4048.3 | 1165.6 | 2128.7 | 3.27  |       |
| TAP 6           | TAP 6     | 0.2      | 3087.8 | 703.8  | 675.2  | 0.97  |       |
|                 |           | 0.4      | 2915.4 | 758.8  | 717.4  | 1.04  |       |
|                 |           | 0.6      | 2732.6 | 807.2  | 753.9  | 1.11  |       |
|                 |           | 0.8      | 2586.1 | 850.1  | 788.7  | 1.17  |       |
|                 |           | 1        | 2395.5 | 899.1  | 840.7  | 1.23  |       |
|                 |           | 1.2      | 2172.6 | 951.9  | 888.6  | 1.31  |       |
|                 |           | 1.4      | 2007.2 | 989.8  | 926.4  | 1.36  |       |
| TAP 7           | TAP 7     | 0.2      | 3941.2 | 844.7  | 1180.5 | 1.72  |       |
|                 |           | 0.4      | 3830.1 | 879.9  | 1221.4 | 1.79  |       |
|                 |           | 0.6      | 3709.9 | 916.7  | 1260.5 | 1.87  |       |
|                 |           | 0.8      | 3576.1 | 953.6  | 1307.3 | 1.94  |       |
|                 |           | 1        | 3419.1 | 997.1  | 1371.1 | 2.03  |       |
|                 |           | 1.2      | 3235.5 | 1046.4 | 1432.8 | 2.13  |       |
|                 |           | 1.4      | 3088.5 | 1082.6 | 1478.9 | 2.21  |       |
| TAP 8           | TAP 8     | 0.2      | 4619.2 | 958.8  | 1724.5 | 2.59  |       |
|                 |           | 0.4      | 4536.5 | 983.7  | 1768.8 | 2.66  |       |
|                 |           | 0.6      | 4444.2 | 1013.4 | 1814.1 | 2.74  |       |
|                 |           | 0.8      | 4333.9 | 1045.2 | 1868.9 | 2.83  |       |
|                 |           | 1        | 4209.9 | 1081.2 | 1932.5 | 2.92  |       |
|                 |           | 1.2      | 4067.0 | 1123.3 | 1999.7 | 3.04  |       |
|                 |           | 1.4      | 3938.2 | 1156.0 | 2041.3 | 3.13  |       |
| TAP 9           | TAP 9     | 0.2      | 4573.3 | 951.0  | 1681.3 | 2.52  |       |
|                 |           | 0.4      | 4489.6 | 976.3  | 1725.2 | 2.59  |       |
|                 |           | 0.6      | 4395.4 | 1006.4 | 1769.9 | 2.67  |       |
|                 |           | 0.8      | 4283.9 | 1038.6 | 1824.2 | 2.76  |       |
|                 |           | 1        | 4157.3 | 1075.2 | 1888.2 | 2.85  |       |
|                 |           | 1.2      | 4011.3 | 1118.0 | 1955.2 | 2.97  |       |
|                 |           | 1.4      | 3881.0 | 1151.1 | 1997.7 | 3.05  |       |
| TAP 10          | TAP 10    | 0.2      | 4708.0 | 974.0  | 1811.7 | 2.73  |       |
|                 |           | 0.4      | 4626.7 | 998.1  | 1856.9 | 2.80  |       |
|                 |           | 0.6      | 4537.5 | 1027.1 | 1903.5 | 2.88  |       |
|                 |           | 0.8      | 4429.9 | 1058.2 | 1959.1 | 2.97  |       |
|                 |           | 1        | 4310.9 | 1092.9 | 2021.6 | 3.07  |       |
|                 |           | 1.2      | 4174.4 | 1133.5 | 2088.9 | 3.18  |       |
|                 |           | 1.4      | 4048.3 | 1165.6 | 2128.7 | 3.27  |       |

|                 |           | HORIZONTAL |        |        |        |       |       |
|-----------------|-----------|------------|--------|--------|--------|-------|-------|
|                 | TAP SPEED | ESP        | SCFM   | R.F.M. | WATTS  | BHP   |       |
|                 |           | PL Rated   | TAP 1  | 0.2    | 2576.3 | 538.6 | 339.0 |
| 0.4             | 2320.2    |            |        | 628.7  | 390.0  | 0.59  |       |
| 0.6             | 2042.1    |            |        | 706.0  | 438.8  | 0.66  |       |
| 0.8             |           |            |        |        |        |       |       |
| 1               |           |            |        |        |        |       |       |
| 1.2             |           |            |        |        |        |       |       |
| 1.4             |           |            |        |        |        |       |       |
| PL CFM Max      | TAP 2     | 0.2        | 2862.9 | 577.0  | 440.8  | 0.64  |       |
|                 |           | 0.4        | 2632.9 | 657.2  | 491.5  | 0.73  |       |
|                 |           | 0.6        | 2379.1 | 728.2  | 541.6  | 0.81  |       |
|                 |           | 0.8        | 2215.9 | 777.5  | 580.4  | 0.86  |       |
|                 |           | 1          |        |        |        |       |       |
|                 |           | 1.2        |        |        |        |       |       |
|                 |           | 1.4        |        |        |        |       |       |
| Rated @ 0.8 ESP | TAP 3     | 0.2        | 3676.9 | 686.6  | 781.6  | 1.12  |       |
|                 |           | 0.4        | 3513.5 | 741.3  | 832.1  | 1.21  |       |
|                 |           | 0.6        | 3324.1 | 795.4  | 886.2  | 1.30  |       |
|                 |           | 0.8        | 3182.4 | 841.0  | 936.3  | 1.37  |       |
|                 |           | 1          | 2976.8 | 898.0  | 983.1  | 1.47  |       |
|                 |           | 1.2        | 2843.9 | 938.3  | 1027.6 | 1.53  |       |
|                 |           | 1.4        | 2562.7 | 1019.8 | 1105.8 | 1.67  |       |
| 400 CFM/Ton     | TAP 4     | 0.2        | 4904.5 | 854.1  | 1539.2 | 2.27  |       |
|                 |           | 0.4        | 4805.6 | 882.0  | 1593.0 | 2.34  |       |
|                 |           | 0.6        | 4692.3 | 916.2  | 1654.7 | 2.43  |       |
|                 |           | 0.8        | 4580.2 | 953.9  | 1713.8 | 2.53  |       |
|                 |           | 1          | 4422.6 | 1001.6 | 1782.5 | 2.66  |       |
|                 |           | 1.2        | 4332.7 | 1023.6 | 1826.8 | 2.72  |       |
|                 |           | 1.4        | 4160.2 | 1066.7 | 1911.9 | 2.83  |       |
| 400 CFM/Ton     | TAP 5     | 0.2        | 5050.1 | 874.3  | 1664.7 | 2.45  |       |
|                 |           | 0.4        | 4953.6 | 900.8  | 1719.5 | 2.53  |       |
|                 |           | 0.6        | 4846.3 | 933.4  | 1782.3 | 2.62  |       |
|                 |           | 0.8        | 4737.2 | 969.8  | 1841.2 | 2.72  |       |
|                 |           | 1          | 4589.0 | 1015.3 | 1912.7 | 2.85  |       |
|                 |           | 1.2        | 4501.4 | 1036.8 | 1958.2 | 2.91  |       |
|                 |           | 1.4        | 4342.8 | 1076.5 | 2042.7 | 3.02  |       |
| TAP 6           | TAP 6     | 0.2        | 3289.1 | 634.3  | 608.5  | 0.87  |       |
|                 |           | 0.4        | 3095.5 | 700.6  | 658.9  | 0.96  |       |
|                 |           | 0.6        | 2876.4 | 762.6  | 711.0  | 1.05  |       |
|                 |           | 0.8        | 2724.5 | 810.0  | 756.1  | 1.11  |       |
|                 |           | 1          | 2510.5 | 868.0  | 796.3  | 1.19  |       |
|                 |           | 1.2        | 2358.9 | 917.0  | 843.1  | 1.26  |       |
|                 |           | 1.4        | 2045.1 | 1012.8 | 916.6  | 1.39  |       |
| TAP 7           | TAP 7     | 0.2        | 4218.7 | 760.1  | 1066.7 | 1.55  |       |
|                 |           | 0.4        | 4091.0 | 800.6  | 1117.9 | 1.63  |       |
|                 |           | 0.6        | 3939.4 | 844.8  | 1175.1 | 1.72  |       |
|                 |           | 0.8        | 3811.3 | 887.4  | 1230.8 | 1.81  |       |
|                 |           | 1          | 3622.0 | 941.8  | 1287.0 | 1.92  |       |
|                 |           | 1.2        | 3511.9 | 971.8  | 1329.8 | 1.98  |       |
|                 |           | 1.4        | 3277.3 | 1034.7 | 1412.9 | 2.11  |       |
| TAP 8           | TAP 8     | 0.2        | 4954.2 | 860.9  | 1580.7 | 2.33  |       |
|                 |           | 0.4        | 4856.3 | 888.4  | 1634.9 | 2.40  |       |
|                 |           | 0.6        | 4745.1 | 922.0  | 1696.9 | 2.49  |       |
|                 |           | 0.8        | 4634.1 | 959.2  | 1756.0 | 2.59  |       |
|                 |           | 1          | 4479.6 | 1006.3 | 1825.6 | 2.72  |       |
|                 |           | 1.2        | 4390.6 | 1028.0 | 1870.3 | 2.78  |       |
|                 |           | 1.4        | 4222.8 | 1069.9 | 1955.2 | 2.89  |       |
| TAP 9           | TAP 9     | 0.2        | 4904.5 | 854.1  | 1539.2 | 2.27  |       |
|                 |           | 0.4        | 4805.6 | 882.0  | 1593.0 | 2.34  |       |
|                 |           | 0.6        | 4692.3 | 916.2  | 1654.7 | 2.43  |       |
|                 |           | 0.8        | 4580.2 | 953.9  | 1713.8 | 2.53  |       |
|                 |           | 1          | 4422.6 | 1001.6 | 1782.5 | 2.66  |       |
|                 |           | 1.2        | 4332.7 | 1023.6 | 1826.8 | 2.72  |       |
|                 |           | 1.4        | 4160.2 | 1066.7 | 1911.9 | 2.83  |       |
| TAP 10          | TAP 10    | 0.2        | 5050.1 | 874.3  | 1664.7 | 2.45  |       |
|                 |           | 0.4        | 4953.6 | 900.8  | 1719.5 | 2.53  |       |
|                 |           | 0.6        | 4846.3 | 933.4  | 1782.3 | 2.62  |       |
|                 |           | 0.8        | 4737.2 | 969.8  | 1841.2 | 2.72  |       |
|                 |           | 1          | 4589.0 | 1015.3 | 1912.7 | 2.85  |       |
|                 |           | 1.2        | 4501.4 | 1036.8 | 1958.2 | 2.91  |       |
|                 |           | 1.4        | 4342.8 | 1076.5 | 2042.7 | 3.02  |       |



# APPENDIX A BLOWER PERFORMANCE DATA

## 12.5 TON GE

12.5T 130K 5 burner Standard Static

Motor 3.5 HP

Model: DSG150\_STD

### DOWNSHOT

### HORIZONTAL

|                       |        | TAP SPEED | ESP    | SCFM  | R.F.M. | WATTS | BHP |
|-----------------------|--------|-----------|--------|-------|--------|-------|-----|
| PL Rated              | TAP 1  | 0.2       | 2212.1 | 510.9 | 226.7  | 0.33  |     |
|                       |        | 0.4       | 1878.6 | 608.8 | 270.5  | 0.40  |     |
|                       |        | 0.6       | 1656.4 | 664.5 | 293.0  | 0.43  |     |
|                       |        | 0.8       | 1435.7 | 713.6 | 312.1  | 0.46  |     |
| PL Max CFM            | TAP 2  | 0.2       | 2495.2 | 550.3 | 308.7  | 0.45  |     |
|                       |        | 0.4       | 2213.3 | 635.9 | 351.7  | 0.53  |     |
|                       |        | 0.6       | 2021.9 | 688.5 | 376.8  | 0.57  |     |
|                       |        | 0.8       | 1800.8 | 741.2 | 404.7  | 0.61  |     |
| Rated                 | TAP 3  | 0.2       | 4262.4 | 803.3 | 1088.3 | 1.79  |     |
|                       |        | 0.4       | 4181.1 | 839.0 | 1137.3 | 1.87  |     |
|                       |        | 0.6       | 4086.9 | 876.3 | 1181.9 | 1.96  |     |
|                       |        | 0.8       | 3950.6 | 922.9 | 1237.3 | 2.06  |     |
| 350 CFM/Ton @ 0.6 ESP | TAP 4  | 0.2       | 4637.0 | 860.2 | 1378.5 | 2.30  |     |
|                       |        | 0.4       | 4541.8 | 897.8 | 1434.4 | 2.40  |     |
|                       |        | 0.6       | 4423.6 | 933.7 | 1484.2 | 2.50  |     |
|                       |        | 0.8       | 4346.2 | 965.7 | 1532.7 | 2.58  |     |
| 354 CFM/Ton@.8        | TAP 5  | 0.2       | 4718.1 | 872.9 | 1455.3 | 2.43  |     |
|                       |        | 0.4       | 4613.5 | 912.3 | 1513.3 | 2.54  |     |
|                       |        | 0.6       | 4485.1 | 948.1 | 1564.4 | 2.64  |     |
|                       |        | 0.8       | 4425.1 | 975.5 | 1609.9 | 2.72  |     |
|                       | TAP 6  | 0.2       | 1654.6 | 433.8 | 84.6   | 0.14  |     |
|                       |        | 0.4       |        |       |        |       |     |
|                       |        | 0.6       |        |       |        |       |     |
|                       |        | 0.8       |        |       |        |       |     |
|                       | TAP 7  | 0.2       | 1899.2 | 467.5 | 144.0  | 0.15  |     |
|                       |        | 0.4       | 1505.2 | 579.8 | 189.3  | 0.19  |     |
|                       |        | 0.6       |        |       |        |       |     |
|                       |        | 0.8       |        |       |        |       |     |
|                       | TAP 8  | 0.2       | 2135.3 | 500.2 | 205.6  | 0.30  |     |
|                       |        | 0.4       | 1787.3 | 601.6 | 249.8  | 0.36  |     |
|                       |        | 0.6       | 1556.2 | 658.1 | 271.5  | 0.40  |     |
|                       |        | 0.8       |        |       |        |       |     |
| 350 CFM/Ton @ 0.6 ESP | TAP 9  | 0.2       | 4637.0 | 860.2 | 1378.5 | 2.30  |     |
|                       |        | 0.4       | 4541.8 | 897.8 | 1434.4 | 2.40  |     |
|                       |        | 0.6       | 4423.6 | 933.7 | 1484.2 | 2.50  |     |
|                       |        | 0.8       | 4346.2 | 965.7 | 1532.7 | 2.58  |     |
| 354 CFM/Ton@.8        | TAP 10 | 0.2       | 4718.1 | 872.9 | 1455.3 | 2.43  |     |
|                       |        | 0.4       | 4613.5 | 912.3 | 1513.3 | 2.54  |     |
|                       |        | 0.6       | 4485.1 | 948.1 | 1564.4 | 2.64  |     |
|                       |        | 0.8       | 4425.1 | 975.5 | 1609.9 | 2.72  |     |

|                       |        | TAP SPEED | ESP    | SCFM  | R.F.M. | WATTS | BHP |
|-----------------------|--------|-----------|--------|-------|--------|-------|-----|
| PL Rated @ 0.15 ESP   | TAP 1  | 0.2       | 2299.1 | 481.1 | 216.7  | 0.31  |     |
|                       |        | 0.4       | 2056.2 | 572.5 | 257.4  | 0.37  |     |
|                       |        | 0.6       | 1746.5 | 660.3 | 291.4  | 0.43  |     |
|                       |        | 0.8       | 1567.9 | 711.3 | 294.0  | 0.46  |     |
| PL Max CFM @ 0.35 ESP | TAP 2  | 0.2       | 2587.0 | 516.0 | 286.6  | 0.43  |     |
|                       |        | 0.4       | 2382.2 | 596.2 | 327.5  | 0.49  |     |
|                       |        | 0.6       | 2116.5 | 675.6 | 365.4  | 0.56  |     |
|                       |        | 0.8       | 1946.5 | 727.8 | 378.9  | 0.60  |     |
| Rated @ 0.35 ESP      | TAP 3  | 0.2       | 4385.0 | 747.1 | 1013.1 | 1.67  |     |
|                       |        | 0.4       | 4313.1 | 784.1 | 1058.8 | 1.75  |     |
|                       |        | 0.6       | 4233.4 | 824.6 | 1120.7 | 1.84  |     |
|                       |        | 0.8       | 4130.9 | 869.0 | 1175.1 | 1.94  |     |
| 365 CFM/Ton @ 0.6 ESP | TAP 4  | 0.2       | 4766.7 | 802.3 | 1302.9 | 2.14  |     |
|                       |        | 0.4       | 4673.7 | 842.7 | 1351.2 | 2.25  |     |
|                       |        | 0.6       | 4592.3 | 881.0 | 1418.0 | 2.36  |     |
|                       |        | 0.8       | 4510.3 | 916.9 | 1468.4 | 2.45  |     |
| 365 CFM/Ton@.8        | TAP 5  | 0.2       | 4849.3 | 815.0 | 1380.8 | 2.27  |     |
|                       |        | 0.4       | 4746.3 | 857.5 | 1429.8 | 2.39  |     |
|                       |        | 0.6       | 4659.9 | 896.0 | 1497.7 | 2.50  |     |
|                       |        | 0.8       | 4583.0 | 929.3 | 1545.7 | 2.59  |     |
|                       | TAP 6  | 0.2       | 1732.3 | 413.4 | 100.4  | 0.13  |     |
|                       |        | 0.4       | 1406.5 | 528.9 | 140.9  | 0.17  |     |
|                       |        | 0.6       |        |       |        |       |     |
|                       |        | 0.8       |        |       |        |       |     |
|                       | TAP 7  | 0.2       | 1981.0 | 443.0 | 148.3  | 0.14  |     |
|                       |        | 0.4       | 1692.7 | 547.6 | 188.8  | 0.18  |     |
|                       |        | 0.6       | 1332.0 | 645.0 | 218.5  | 0.21  |     |
|                       |        | 0.8       |        |       |        |       |     |
|                       | TAP 8  | 0.2       | 2221.0 | 471.7 | 199.1  | 0.28  |     |
|                       |        | 0.4       | 1967.2 | 566.3 | 239.8  | 0.34  |     |
|                       |        | 0.6       | 1645.3 | 656.4 | 272.7  | 0.40  |     |
|                       |        | 0.8       | 1464.3 | 707.0 | 272.2  | 0.43  |     |
| 365 CFM/Ton @ 0.6 ESP | TAP 9  | 0.2       | 4766.7 | 802.3 | 1302.9 | 2.14  |     |
|                       |        | 0.4       | 4673.7 | 842.7 | 1351.2 | 2.25  |     |
|                       |        | 0.6       | 4592.3 | 881.0 | 1418.0 | 2.36  |     |
|                       |        | 0.8       | 4510.3 | 916.9 | 1468.4 | 2.45  |     |
| 365 CFM/Ton@.8        | TAP 10 | 0.2       | 4849.3 | 815.0 | 1380.8 | 2.27  |     |
|                       |        | 0.4       | 4746.3 | 857.5 | 1429.8 | 2.39  |     |
|                       |        | 0.6       | 4659.9 | 896.0 | 1497.7 | 2.50  |     |
|                       |        | 0.8       | 4583.0 | 929.3 | 1545.7 | 2.59  |     |





# APPENDIX A BLOWER PERFORMANCE DATA

## 12.5 TON GE

12.5T 180K 6 burner Standard Static

Motor 3.5 HP

Model: DSG150\_STD

### DOWNSHOT

### HORIZONTAL

|                       |        | DOWNSHOT  |        |        |        |       |     |
|-----------------------|--------|-----------|--------|--------|--------|-------|-----|
|                       |        | TAP SPEED | ESP    | SCFM   | R.P.M. | WATTS | BHP |
| PL Rated @ 0.15 ESP   | TAP 1  | 0.2       | 2192.9 | 557.2  | 268.9  | 0.39  |     |
|                       |        | 0.4       | 1886.6 | 632.8  | 302.4  | 0.45  |     |
|                       |        | 0.6       | 1668.6 | 689.4  | 332.0  | 0.49  |     |
|                       |        | 0.8       | 1467.7 | 736.3  | 354.0  | 0.52  |     |
| PL Max CFM @ 0.35 ESP | TAP 2  | 0.2       | 2471.4 | 599.9  | 355.4  | 0.53  |     |
|                       |        | 0.4       | 2214.4 | 666.2  | 391.2  | 0.59  |     |
|                       |        | 0.6       | 1999.5 | 720.9  | 422.9  | 0.64  |     |
|                       |        | 0.8       | 1783.5 | 772.5  | 452.9  | 0.68  |     |
| Rated @ 0.35 ESP      | TAP 3  | 0.2       | 4276.5 | 902.1  | 1338.6 | 2.24  |     |
|                       |        | 0.4       | 4194.0 | 934.7  | 1385.5 | 2.32  |     |
|                       |        | 0.6       | 4089.6 | 963.7  | 1419.6 | 2.39  |     |
|                       |        | 0.8       | 3949.8 | 999.3  | 1465.9 | 2.48  |     |
| 340 CFM/Ton@.6        | TAP 4  | 0.2       | 4410.4 | 928.5  | 1478.6 | 2.48  |     |
|                       |        | 0.4       | 4318.0 | 962.8  | 1525.8 | 2.57  |     |
|                       |        | 0.6       | 4236.0 | 987.8  | 1558.2 | 2.64  |     |
|                       |        | 0.8       | 4129.6 | 1014.8 | 1600.2 | 2.71  |     |
| 340 CFM/Ton@.8        | TAP 5  | 0.2       | 4486.1 | 944.1  | 1568.7 | 2.63  |     |
|                       |        | 0.4       | 4384.2 | 980.1  | 1616.0 | 2.73  |     |
|                       |        | 0.6       | 4317.2 | 1002.4 | 1647.2 | 2.79  |     |
|                       |        | 0.8       | 4234.2 | 1023.4 | 1685.8 | 2.85  |     |
|                       | TAP 6  | 0.2       | 1953.1 | 520.8  | 201.6  | 0.29  |     |
|                       |        | 0.4       |        |        |        |       |     |
|                       |        | 0.6       |        |        |        |       |     |
|                       |        | 0.8       |        |        |        |       |     |
|                       | TAP 7  | 0.2       | 2464.4 | 598.8  | 353.1  | 0.33  |     |
|                       |        | 0.4       | 2206.2 | 665.4  | 388.8  | 0.37  |     |
|                       |        | 0.6       | 1991.3 | 720.1  | 420.6  | 0.40  |     |
|                       |        | 0.8       |        |        |        |       |     |
|                       | TAP 8  | 0.2       | 2927.3 | 671.2  | 521.0  | 0.81  |     |
|                       |        | 0.4       | 2742.7 | 723.8  | 560.2  | 0.87  |     |
|                       |        | 0.6       | 2538.2 | 774.7  | 594.8  | 0.93  |     |
|                       |        | 0.8       |        |        |        |       |     |
| 340 CFM/Ton@.6        | TAP 9  | 0.2       | 4410.4 | 928.5  | 1478.6 | 2.48  |     |
|                       |        | 0.4       | 4318.0 | 962.8  | 1525.8 | 2.57  |     |
|                       |        | 0.6       | 4236.0 | 987.8  | 1558.2 | 2.64  |     |
|                       |        | 0.8       | 4129.6 | 1014.8 | 1600.2 | 2.71  |     |
| 340 CFM/Ton@.8        | TAP 10 | 0.2       | 4486.1 | 944.1  | 1568.7 | 2.63  |     |
|                       |        | 0.4       | 4384.2 | 980.1  | 1616.0 | 2.73  |     |
|                       |        | 0.6       | 4317.2 | 1002.4 | 1647.2 | 2.79  |     |
|                       |        | 0.8       | 4234.2 | 1023.4 | 1685.8 | 2.85  |     |

|                       |        | HORIZONTAL |        |       |        |       |     |
|-----------------------|--------|------------|--------|-------|--------|-------|-----|
|                       |        | TAP SPEED  | ESP    | SCFM  | R.P.M. | WATTS | BHP |
| PL Rated @ 0.15 ESP   | TAP 1  | 0.2        | 2396.2 | 492.8 | 242.2  | 0.35  |     |
|                       |        | 0.4        | 2213.6 | 572.5 | 283.0  | 0.40  |     |
|                       |        | 0.6        | 1869.9 | 666.1 | 336.4  | 0.47  |     |
|                       |        | 0.8        | 1702.9 | 717.5 | 348.1  | 0.51  |     |
| PL Max CFM @ 0.35 ESP | TAP 2  | 0.2        | 2687.2 | 528.8 | 318.0  | 0.47  |     |
|                       |        | 0.4        | 2526.6 | 601.5 | 362.7  | 0.53  |     |
|                       |        | 0.6        | 2242.9 | 684.3 | 411.8  | 0.61  |     |
|                       |        | 0.8        | 2085.9 | 736.0 | 432.7  | 0.65  |     |
| Rated @ 0.35 ESP      | TAP 3  | 0.2        | 4645.2 | 782.7 | 1179.3 | 1.94  |     |
|                       |        | 0.4        | 4562.3 | 820.2 | 1237.4 | 2.04  |     |
|                       |        | 0.6        | 4489.3 | 860.3 | 1295.4 | 2.14  |     |
|                       |        | 0.8        | 4400.2 | 901.5 | 1344.3 | 2.24  |     |
| 370 CFM/Ton@.6        | TAP 4  | 0.2        | 4801.9 | 804.8 | 1301.9 | 2.15  |     |
|                       |        | 0.4        | 4714.5 | 841.3 | 1359.1 | 2.25  |     |
|                       |        | 0.6        | 4628.9 | 882.7 | 1423.5 | 2.36  |     |
|                       |        | 0.8        | 4545.2 | 921.1 | 1469.6 | 2.46  |     |
| 370 CFM/Ton@.8        | TAP 5  | 0.2        | 4892.4 | 817.9 | 1380.9 | 2.28  |     |
|                       |        | 0.4        | 4800.7 | 854.1 | 1437.2 | 2.38  |     |
|                       |        | 0.6        | 4703.2 | 896.9 | 1506.3 | 2.50  |     |
|                       |        | 0.8        | 4622.8 | 933.3 | 1549.9 | 2.60  |     |
|                       | TAP 6  | 0.2        | 2147.0 | 462.3 | 183.4  | 0.26  |     |
|                       |        | 0.4        | 1944.3 | 548.1 | 220.5  | 0.31  |     |
|                       |        | 0.6        |        |       |        |       |     |
|                       |        | 0.8        |        |       |        |       |     |
|                       | TAP 7  | 0.2        | 2679.9 | 527.9 | 316.0  | 0.29  |     |
|                       |        | 0.4        | 2518.8 | 600.7 | 360.6  | 0.33  |     |
|                       |        | 0.6        | 2233.7 | 683.8 | 409.8  | 0.38  |     |
|                       |        | 0.8        | 2076.4 | 735.6 | 430.5  | 0.41  |     |
|                       | TAP 8  | 0.2        | 3167.5 | 588.8 | 463.0  | 0.71  |     |
|                       |        | 0.4        | 3039.3 | 650.6 | 513.5  | 0.79  |     |
|                       |        | 0.6        | 2843.8 | 717.2 | 557.6  | 0.87  |     |
|                       |        | 0.8        | 2703.4 | 768.9 | 591.8  | 0.93  |     |
| 370 CFM/Ton@.6        | TAP 9  | 0.2        | 4801.9 | 804.8 | 1301.9 | 2.15  |     |
|                       |        | 0.4        | 4714.5 | 841.3 | 1359.1 | 2.25  |     |
|                       |        | 0.6        | 4628.9 | 882.7 | 1423.5 | 2.36  |     |
|                       |        | 0.8        | 4545.2 | 921.1 | 1469.6 | 2.46  |     |
| 370 CFM/Ton@.8        | TAP 10 | 0.2        | 4892.4 | 817.9 | 1380.9 | 2.28  |     |
|                       |        | 0.4        | 4800.7 | 854.1 | 1437.2 | 2.38  |     |
|                       |        | 0.6        | 4703.2 | 896.9 | 1506.3 | 2.50  |     |
|                       |        | 0.8        | 4622.8 | 933.3 | 1549.9 | 2.60  |     |







# APPENDIX A BLOWER PERFORMANCE DATA

## 12.5 TON GE

12.5T 240K 7 burner Standard Static

Motor 3.5 HP

Model: DSG150\_STD

### DOWNSHOT

### HORIZONTAL

|                       |        | DOWNSHOT  |        |        |        |       |     |
|-----------------------|--------|-----------|--------|--------|--------|-------|-----|
|                       |        | TAP SPEED | ESP    | SCFM   | R.P.M. | WATTS | BHP |
| PL Rated @ 0.15 ESP   | TAP 1  | 0.2       | 2200.9 | 591.0  | 313.5  | 0.45  |     |
|                       |        | 0.4       | 1963.0 | 656.1  | 344.1  | 0.50  |     |
|                       |        | 0.6       | 1756.6 | 706.7  | 366.5  | 0.54  |     |
|                       |        | 0.8       | 1556.9 | 749.9  | 393.0  | 0.57  |     |
| PL Max CFM @ 0.35 ESP | TAP 2  | 0.2       | 2378.3 | 617.3  | 370.7  | 0.54  |     |
|                       |        | 0.4       | 2159.3 | 678.2  | 403.2  | 0.60  |     |
|                       |        | 0.6       | 1952.0 | 730.1  | 428.7  | 0.64  |     |
|                       |        | 0.8       | 1744.5 | 776.0  | 458.4  | 0.68  |     |
| Rated @ 0.35 ESP      | TAP 3  | 0.2       | 4170.2 | 910.1  | 1348.2 | 2.26  |     |
|                       |        | 0.4       | 4067.1 | 937.6  | 1389.8 | 2.33  |     |
|                       |        | 0.6       | 3940.7 | 973.8  | 1436.2 | 2.42  |     |
|                       |        | 0.8       | 3784.1 | 1010.3 | 1481.2 | 2.51  |     |
| 320 CFM/Ton@.6        | TAP 4  | 0.2       | 4268.2 | 929.4  | 1449.8 | 2.44  |     |
|                       |        | 0.4       | 4162.5 | 956.2  | 1490.6 | 2.51  |     |
|                       |        | 0.6       | 4051.3 | 988.0  | 1536.9 | 2.59  |     |
|                       |        | 0.8       | 3913.0 | 1019.6 | 1580.7 | 2.67  |     |
| 320 CFM/Ton@.8        | TAP 5  | 0.2       | 4370.9 | 950.6  | 1571.5 | 2.65  |     |
|                       |        | 0.4       | 4259.4 | 977.2  | 1611.3 | 2.72  |     |
|                       |        | 0.6       | 4167.7 | 1003.2 | 1657.1 | 2.79  |     |
|                       |        | 0.8       | 4053.6 | 1028.1 | 1698.9 | 2.86  |     |
|                       | TAP 6  | 0.2       | 2713.7 | 667.8  | 490.8  | 0.74  |     |
|                       |        | 0.4       | 2528.3 | 720.9  | 526.5  | 0.80  |     |
|                       |        | 0.6       |        |        |        |       |     |
|                       |        | 0.8       |        |        |        |       |     |
|                       | TAP 7  | 0.2       | 3440.0 | 782.2  | 822.9  | 0.87  |     |
|                       |        | 0.4       | 3313.6 | 820.1  | 863.9  | 0.91  |     |
|                       |        | 0.6       | 3125.6 | 872.1  | 905.0  | 0.97  |     |
|                       |        | 0.8       | 2907.2 | 924.3  | 949.3  | 1.03  |     |
|                       | TAP 8  | 0.2       | 4005.8 | 879.3  | 1200.9 | 2.00  |     |
|                       |        | 0.4       | 3902.9 | 908.4  | 1243.1 | 2.07  |     |
|                       |        | 0.6       | 3756.1 | 950.4  | 1289.0 | 2.16  |     |
|                       |        | 0.8       | 3576.2 | 993.1  | 1335.2 | 2.26  |     |
| 320 CFM/Ton@.6        | TAP 9  | 0.2       | 4268.2 | 929.4  | 1449.8 | 2.44  |     |
|                       |        | 0.4       | 4162.5 | 956.2  | 1490.6 | 2.51  |     |
|                       |        | 0.6       | 4051.3 | 988.0  | 1536.9 | 2.59  |     |
|                       |        | 0.8       | 3913.0 | 1019.6 | 1580.7 | 2.67  |     |
| 320 CFM/Ton@.8        | TAP 10 | 0.2       | 4370.9 | 950.6  | 1571.5 | 2.65  |     |
|                       |        | 0.4       | 4259.4 | 977.2  | 1611.3 | 2.72  |     |
|                       |        | 0.6       | 4167.7 | 1003.2 | 1657.1 | 2.79  |     |
|                       |        | 0.8       | 4053.6 | 1028.1 | 1698.9 | 2.86  |     |

|                       |        | HORIZONTAL |        |       |        |       |     |
|-----------------------|--------|------------|--------|-------|--------|-------|-----|
|                       |        | TAP SPEED  | ESP    | SCFM  | R.P.M. | WATTS | BHP |
| PL Rated @ 0.15 ESP   | TAP 1  | 0.2        | 2475.9 | 504.7 | 276.2  | 0.39  |     |
|                       |        | 0.4        | 2292.5 | 577.5 | 309.1  | 0.44  |     |
|                       |        | 0.6        | 1964.7 | 669.6 | 351.8  | 0.51  |     |
|                       |        | 0.8        | 1791.5 | 721.7 | 378.4  | 0.55  |     |
| PL Max CFM @ 0.35 ESP | TAP 2  | 0.2        | 2659.0 | 527.0 | 323.1  | 0.46  |     |
|                       |        | 0.4        | 2489.0 | 596.0 | 357.8  | 0.53  |     |
|                       |        | 0.6        | 2199.4 | 680.2 | 399.2  | 0.60  |     |
|                       |        | 0.8        | 2034.7 | 732.6 | 430.6  | 0.65  |     |
| Rated @ 0.35 ESP      | TAP 3  | 0.2        | 4604.0 | 773.9 | 1166.1 | 1.92  |     |
|                       |        | 0.4        | 4517.9 | 814.3 | 1217.4 | 2.02  |     |
|                       |        | 0.6        | 4441.7 | 853.1 | 1277.2 | 2.12  |     |
|                       |        | 0.8        | 4348.2 | 894.7 | 1332.4 | 2.22  |     |
| 360 CFM/Ton@.6        | TAP 4  | 0.2        | 4721.9 | 790.0 | 1256.6 | 2.07  |     |
|                       |        | 0.4        | 4634.1 | 830.0 | 1308.8 | 2.18  |     |
|                       |        | 0.6        | 4548.9 | 870.4 | 1373.3 | 2.28  |     |
|                       |        | 0.8        | 4457.5 | 909.9 | 1426.8 | 2.39  |     |
| 360 CFM/Ton@.8        | TAP 5  | 0.2        | 4849.1 | 807.7 | 1365.7 | 2.25  |     |
|                       |        | 0.4        | 4757.4 | 847.6 | 1418.7 | 2.36  |     |
|                       |        | 0.6        | 4656.1 | 891.0 | 1489.4 | 2.48  |     |
|                       |        | 0.8        | 4566.5 | 927.8 | 1540.3 | 2.58  |     |
|                       | TAP 6  | 0.2        | 3008.0 | 569.8 | 422.8  | 0.63  |     |
|                       |        | 0.4        | 2862.0 | 632.0 | 460.6  | 0.70  |     |
|                       |        | 0.6        | 2639.6 | 702.3 | 500.6  | 0.78  |     |
|                       |        | 0.8        |        |       |        |       |     |
|                       | TAP 7  | 0.2        | 3781.0 | 666.4 | 705.3  | 0.74  |     |
|                       |        | 0.4        | 3677.5 | 715.4 | 750.0  | 0.80  |     |
|                       |        | 0.6        | 3569.1 | 761.9 | 792.4  | 0.85  |     |
|                       |        | 0.8        | 3451.2 | 812.0 | 845.6  | 0.90  |     |
|                       | TAP 8  | 0.2        | 4411.7 | 748.1 | 1035.5 | 1.70  |     |
|                       |        | 0.4        | 4325.5 | 789.8 | 1085.4 | 1.80  |     |
|                       |        | 0.6        | 4254.7 | 827.8 | 1139.0 | 1.88  |     |
|                       |        | 0.8        | 4156.7 | 872.3 | 1195.5 | 1.98  |     |
| 360 CFM/Ton@.6        | TAP 9  | 0.2        | 4721.9 | 790.0 | 1256.6 | 2.07  |     |
|                       |        | 0.4        | 4634.1 | 830.0 | 1308.8 | 2.18  |     |
|                       |        | 0.6        | 4548.9 | 870.4 | 1373.3 | 2.28  |     |
|                       |        | 0.8        | 4457.5 | 909.9 | 1426.8 | 2.39  |     |
| 360 CFM/Ton@.8        | TAP 10 | 0.2        | 4849.1 | 807.7 | 1365.7 | 2.25  |     |
|                       |        | 0.4        | 4757.4 | 847.6 | 1418.7 | 2.36  |     |
|                       |        | 0.6        | 4656.1 | 891.0 | 1489.4 | 2.48  |     |
|                       |        | 0.8        | 4566.5 | 927.8 | 1540.3 | 2.58  |     |





# APPENDIX B ELECTRICAL DATA

## ELECTRICAL DATA

| Model Number | Electrical Rating | Compressor |      |      | Outdoor Fan Motor |      |      | Indoor Fan Motor |     |      | Optional Powered Convenience Outlet | Optional Power Exhaust | Power Supply |       |
|--------------|-------------------|------------|------|------|-------------------|------|------|------------------|-----|------|-------------------------------------|------------------------|--------------|-------|
|              |                   | QTY        | RLA  | LRA  | QTY               | HP   | FLA  | QTY              | HP  | FLA  | FLA                                 | FLA                    | MCA          | MOP   |
| DSG0903D     | 208/230/3/60      | 2          | 12.2 | 120  | 2                 | 0.33 | 2.0  | 1                | 2.4 | 8.0  | -                                   | -                      | 39.4/39.4    | 50/50 |
|              |                   |            |      |      |                   |      |      |                  |     |      | 9.6/8.7                             | -                      | 49.0/48.1    | 60/60 |
|              |                   |            |      |      |                   |      |      |                  |     |      | -                                   | 3.3/3.0 (2.4)          | 42.7/42.4    | 50/50 |
|              |                   |            |      |      |                   |      |      |                  |     |      | 9.6/8.7                             | 3.3/3.0 (2.4)          | 52.3/51.1    | 60/60 |
| DSG0903L     | 208/230/3/60      | 2          | 12.2 | 120  | 2                 | 0.33 | 2.0  | 1                | 2.4 | 8.0  | -                                   | -                      | 39.4/39.4    | 50/50 |
|              |                   |            |      |      |                   |      |      |                  |     |      | 9.6/8.7                             | -                      | 49.0/48.1    | 60/60 |
|              |                   |            |      |      |                   |      |      |                  |     |      | -                                   | 3.3/3.0 (2.4)          | 42.7/42.4    | 50/50 |
|              |                   |            |      |      |                   |      |      |                  |     |      | 9.6/8.7                             | 3.3/3.0 (2.4)          | 52.3/51.1    | 60/60 |
| DSG0903W     | 208/230/3/60      | 2          | 12.2 | 120  | 2                 | 0.33 | 2.0  | 1                | 3.5 | 10.9 | -                                   | -                      | 42.3/42.3    | 50/50 |
|              |                   |            |      |      |                   |      |      |                  |     |      | 9.6/8.7                             | -                      | 51.9/51.0    | 60/60 |
|              |                   |            |      |      |                   |      |      |                  |     |      | -                                   | 3.3/3.0 (2.4)          | 45.6/45.3    | 50/50 |
|              |                   |            |      |      |                   |      |      |                  |     |      | 9.6/8.7                             | 3.3/3.0 (2.4)          | 55.2/54.0    | 60/60 |
| DSG0904D     | 460/3/60          | 2          | 5.8  | 55.1 | 2                 | 0.33 | 0.85 | 1                | 2.4 | 5.4  | -                                   | -                      | 20.1         | 25    |
|              |                   |            |      |      |                   |      |      |                  |     |      | 4.3                                 | -                      | 24.4         | 30    |
|              |                   |            |      |      |                   |      |      |                  |     |      | -                                   | 1.2 (1.0)              | 21.3         | 25    |
|              |                   |            |      |      |                   |      |      |                  |     |      | 4.3                                 | 1.2 (1.0)              | 25.6         | 30    |
| DSG0904L     | 460/3/60          | 2          | 5.8  | 55.1 | 2                 | 0.33 | 0.85 | 1                | 2.4 | 5.4  | -                                   | -                      | 20.1         | 25    |
|              |                   |            |      |      |                   |      |      |                  |     |      | 4.3                                 | -                      | 24.4         | 30    |
|              |                   |            |      |      |                   |      |      |                  |     |      | -                                   | 1.2 (1.0)              | 21.3         | 25    |
|              |                   |            |      |      |                   |      |      |                  |     |      | 4.3                                 | 1.2 (1.0)              | 25.6         | 30    |
| DSG0904W     | 460/3/60          | 2          | 5.8  | 55.1 | 2                 | 0.33 | 0.85 | 1                | 3.5 | 7.2  | -                                   | -                      | 21.9         | 25    |
|              |                   |            |      |      |                   |      |      |                  |     |      | 4.3                                 | -                      | 26.2         | 30    |
|              |                   |            |      |      |                   |      |      |                  |     |      | -                                   | 1.2 (1.0)              | 23.1         | 30    |
|              |                   |            |      |      |                   |      |      |                  |     |      | 4.3                                 | 1.2 (1.0)              | 27.4         | 30    |
| DSG0907D     | 575/3/60          | 2          | 5.8  | 41.0 | 2                 | 0.33 | 0.67 | 1                | 2.4 | 4.0  | -                                   | -                      | 18.3         | 20    |
|              |                   |            |      |      |                   |      |      |                  |     |      | 3.5                                 | -                      | 21.8         | 25    |
|              |                   |            |      |      |                   |      |      |                  |     |      | -                                   | 1.3                    | 19.6         | 25    |
|              |                   |            |      |      |                   |      |      |                  |     |      | 3.5                                 | 1.3                    | 23.1         | 25    |
| DSG0907L     | 575/3/60          | 2          | 5.8  | 41.0 | 2                 | 0.33 | 0.67 | 1                | 2.4 | 4.0  | -                                   | -                      | 18.3         | 20    |
|              |                   |            |      |      |                   |      |      |                  |     |      | 3.5                                 | -                      | 21.8         | 25    |
|              |                   |            |      |      |                   |      |      |                  |     |      | -                                   | 1.3                    | 19.6         | 25    |
|              |                   |            |      |      |                   |      |      |                  |     |      | 3.5                                 | 1.3                    | 23.1         | 25    |
| DSG0907W     | 575/3/60          | 2          | 5.8  | 41.0 | 2                 | 0.33 | 0.67 | 1                | 3.5 | 5.0  | -                                   | -                      | 19.3         | 25    |
|              |                   |            |      |      |                   |      |      |                  |     |      | 3.5                                 | -                      | 22.8         | 25    |
|              |                   |            |      |      |                   |      |      |                  |     |      | -                                   | 1.3                    | 20.6         | 25    |
|              |                   |            |      |      |                   |      |      |                  |     |      | 3.5                                 | 1.3                    | 24.1         | 25    |

# APPENDIX B ELECTRICAL DATA

## ELECTRICAL DATA

| Model Number | Electrical Rating | Compressor |      |      | Outdoor Fan Motor |      |      | Indoor Fan Motor |     |      | Optional Powered Convenience Outlet | Optional Power Exhaust | Power Supply |       |
|--------------|-------------------|------------|------|------|-------------------|------|------|------------------|-----|------|-------------------------------------|------------------------|--------------|-------|
|              |                   | QTY        | RLA  | LRA  | QTY               | HP   | FLA  | QTY              | HP  | FLA  | FLA                                 | FLA                    | MCA          | MOP   |
| DSG1023D     | 208/230/3/60      | 2          | 14.1 | 120  | 2                 | 0.33 | 2.0  | 1                | 2.4 | 8.0  | -                                   | -                      | 43.7/43.7    | 50/50 |
|              |                   |            |      |      |                   |      |      |                  |     |      | 9.6/8.7                             | -                      | 53.3/52.4    | 60/60 |
|              |                   |            |      |      |                   |      |      |                  |     |      | -                                   | 3.3/3.0 (2.4)          | 47.0/46.7    | 60/60 |
|              |                   |            |      |      |                   |      |      |                  |     |      | 9.6/8.7                             | 3.3/3.0 (2.4)          | 56.6/55.4    | 60/60 |
| DSG1023L     | 208/230/3/60      | 2          | 14.1 | 120  | 2                 | 0.33 | 2.0  | 1                | 3.5 | 10.9 | -                                   | -                      | 46.6/46.6    | 60/60 |
|              |                   |            |      |      |                   |      |      |                  |     |      | 9.6/8.7                             | -                      | 56.2/55.3    | 70/60 |
|              |                   |            |      |      |                   |      |      |                  |     |      | -                                   | 3.3/3.0 (2.4)          | 49.9/49.6    | 60/60 |
|              |                   |            |      |      |                   |      |      |                  |     |      | 9.6/8.7                             | 3.3/3.0 (2.4)          | 59.5/58.3    | 70/70 |
| DSG1023W     | 208/230/3/60      | 2          | 14.1 | 120  | 2                 | 0.33 | 2.0  | 1                | 3.5 | 10.9 | -                                   | -                      | 46.6/46.6    | 60/60 |
|              |                   |            |      |      |                   |      |      |                  |     |      | 9.6/8.7                             | -                      | 56.2/55.3    | 70/60 |
|              |                   |            |      |      |                   |      |      |                  |     |      | -                                   | 3.3/3.0 (2.4)          | 49.9/49.6    | 60/60 |
|              |                   |            |      |      |                   |      |      |                  |     |      | 9.6/8.7                             | 3.3/3.0 (2.4)          | 59.5/58.3    | 70/70 |
| DSG1024D     | 460/3/60          | 2          | 6.4  | 55.1 | 2                 | 0.33 | 0.85 | 1                | 2.4 | 5.4  | -                                   | -                      | 21.5         | 25    |
|              |                   |            |      |      |                   |      |      |                  |     |      | 4.3                                 | -                      | 25.8         | 30    |
|              |                   |            |      |      |                   |      |      |                  |     |      | -                                   | 1.2 (1.0)              | 22.7         | 25    |
|              |                   |            |      |      |                   |      |      |                  |     |      | 4.3                                 | 1.2 (1.0)              | 27.0         | 30    |
| DSG1024L     | 460/3/60          | 2          | 6.4  | 55.1 | 2                 | 0.33 | 0.85 | 1                | 3.5 | 7.2  | -                                   | -                      | 23.3         | 30    |
|              |                   |            |      |      |                   |      |      |                  |     |      | 4.3                                 | -                      | 27.6         | 35    |
|              |                   |            |      |      |                   |      |      |                  |     |      | -                                   | 1.2 (1.0)              | 24.5         | 30    |
|              |                   |            |      |      |                   |      |      |                  |     |      | 4.3                                 | 1.2 (1.0)              | 28.8         | 35    |
| DSG1024W     | 460/3/60          | 2          | 6.4  | 55.1 | 2                 | 0.33 | 0.85 | 1                | 3.5 | 7.2  | -                                   | -                      | 23.3         | 30    |
|              |                   |            |      |      |                   |      |      |                  |     |      | 4.3                                 | -                      | 27.6         | 35    |
|              |                   |            |      |      |                   |      |      |                  |     |      | -                                   | 1.2 (1.0)              | 24.5         | 30    |
|              |                   |            |      |      |                   |      |      |                  |     |      | 4.3                                 | 1.2 (1.0)              | 28.8         | 35    |
| DSG1027D     | 575/3/60          | 2          | 5.1  | 41.0 | 2                 | 0.33 | 0.67 | 1                | 2.4 | 4.0  | -                                   | -                      | 16.9         | 20    |
|              |                   |            |      |      |                   |      |      |                  |     |      | 3.5                                 | -                      | 20.4         | 25    |
|              |                   |            |      |      |                   |      |      |                  |     |      | -                                   | 1.3                    | 18.2         | 20    |
|              |                   |            |      |      |                   |      |      |                  |     |      | 3.5                                 | 1.3                    | 21.7         | 25    |
| DSG1027L     | 575/3/60          | 2          | 5.1  | 41.0 | 2                 | 0.33 | 0.67 | 1                | 3.5 | 5.0  | -                                   | -                      | 17.9         | 20    |
|              |                   |            |      |      |                   |      |      |                  |     |      | 3.5                                 | -                      | 21.4         | 25    |
|              |                   |            |      |      |                   |      |      |                  |     |      | -                                   | 1.3                    | 19.2         | 20    |
|              |                   |            |      |      |                   |      |      |                  |     |      | 3.5                                 | 1.3                    | 22.7         | 25    |
| DSG1027W     | 575/3/60          | 2          | 5.1  | 41.0 | 2                 | 0.33 | 0.67 | 1                | 3.5 | 5.0  | -                                   | -                      | 17.9         | 20    |
|              |                   |            |      |      |                   |      |      |                  |     |      | 3.5                                 | -                      | 21.4         | 25    |
|              |                   |            |      |      |                   |      |      |                  |     |      | -                                   | 1.3                    | 19.2         | 20    |
|              |                   |            |      |      |                   |      |      |                  |     |      | 3.5                                 | 1.3                    | 22.7         | 25    |
| DSG1203D     | 208/230/3/60      | 2          | 17.3 | 155  | 2                 | 0.33 | 2.0  | 1                | 3.5 | 10.9 | -                                   | -                      | 53.8/53.8    | 70/70 |
|              |                   |            |      |      |                   |      |      |                  |     |      | 9.6/8.7                             | -                      | 63.4/62.5    | 80/70 |
|              |                   |            |      |      |                   |      |      |                  |     |      | -                                   | 3.3/3.0 (2.4)          | 57.1/56.8    | 70/70 |
|              |                   |            |      |      |                   |      |      |                  |     |      | 9.6/8.7                             | 3.3/3.0 (2.4)          | 66.7/65.5    | 80/80 |
| DSG1203L     | 208/230/3/60      | 2          | 17.3 | 155  | 2                 | 0.33 | 2.0  | 1                | 5.0 | 14.5 | -                                   | -                      | 57.4/57.4    | 70/70 |
|              |                   |            |      |      |                   |      |      |                  |     |      | 9.6/8.7                             | -                      | 67.0/66.1    | 80/80 |
|              |                   |            |      |      |                   |      |      |                  |     |      | -                                   | 3.3/3.0 (2.4)          | 60.7/60.4    | 70/70 |
|              |                   |            |      |      |                   |      |      |                  |     |      | 9.6/8.7                             | 3.3/3.0 (2.4)          | 70.3/69.1    | 80/80 |
| DSG1203W     | 208/230/3/60      | 2          | 17.3 | 155  | 2                 | 0.33 | 2.0  | 1                | 5.0 | 14.5 | -                                   | -                      | 57.4/57.4    | 70/70 |
|              |                   |            |      |      |                   |      |      |                  |     |      | 9.6/8.7                             | -                      | 67.0/66.1    | 80/80 |
|              |                   |            |      |      |                   |      |      |                  |     |      | -                                   | 3.3/3.0 (2.4)          | 60.7/60.4    | 70/70 |
|              |                   |            |      |      |                   |      |      |                  |     |      | 9.6/8.7                             | 3.3/3.0 (2.4)          | 70.3/69.1    | 80/80 |

# APPENDIX B ELECTRICAL DATA

## ELECTRICAL DATA

| Model Number | Electrical Rating | Compressor |      |      | Outdoor Fan Motor |      |      | Indoor Fan Motor |     |      | Optional Powered Convenience Outlet | Optional Power Exhaust | Power Supply |       |
|--------------|-------------------|------------|------|------|-------------------|------|------|------------------|-----|------|-------------------------------------|------------------------|--------------|-------|
|              |                   | QTY        | RLA  | LRA  | QTY               | HP   | FLA  | QTY              | HP  | FLA  | FLA                                 | FLA                    | MCA          | MOP   |
| DSG1204D     | 460/3/60          | 2          | 7.7  | 58.1 | 2                 | 0.33 | 0.85 | 1                | 3.5 | 7.2  | -                                   | -                      | 26.2         | 30    |
|              |                   |            |      |      |                   |      |      |                  |     |      | 4.3                                 | -                      | 30.5         | 35    |
|              |                   |            |      |      |                   |      |      |                  |     |      | -                                   | 1.2 (1.0)              | 27.4         | 30    |
|              |                   |            |      |      |                   |      |      |                  |     |      | 4.3                                 | 1.2 (1.0)              | 31.7         | 35    |
| DSG1204L     | 460/3/60          | 2          | 7.7  | 58.1 | 2                 | 0.33 | 0.85 | 1                | 5.0 | 10.6 | -                                   | -                      | 29.6         | 40    |
|              |                   |            |      |      |                   |      |      |                  |     |      | 4.3                                 | -                      | 33.9         | 45    |
|              |                   |            |      |      |                   |      |      |                  |     |      | -                                   | 1.2 (1.0)              | 30.8         | 40    |
|              |                   |            |      |      |                   |      |      |                  |     |      | 4.3                                 | 1.2 (1.0)              | 35.1         | 45    |
| DSG1204W     | 460/3/60          | 2          | 7.7  | 58.1 | 2                 | 0.33 | 0.85 | 1                | 5.0 | 10.6 | -                                   | -                      | 29.6         | 40    |
|              |                   |            |      |      |                   |      |      |                  |     |      | 4.3                                 | -                      | 33.9         | 45    |
|              |                   |            |      |      |                   |      |      |                  |     |      | -                                   | 1.2 (1.0)              | 30.8         | 40    |
|              |                   |            |      |      |                   |      |      |                  |     |      | 4.3                                 | 1.2 (1.0)              | 35.1         | 45    |
| DSG1207D     | 575/3/60          | 2          | 7.0  | 47.8 | 2                 | 0.33 | 0.67 | 1                | 3.5 | 5.0  | -                                   | -                      | 22.2         | 25    |
|              |                   |            |      |      |                   |      |      |                  |     |      | 3.5                                 | -                      | 25.7         | 30    |
|              |                   |            |      |      |                   |      |      |                  |     |      | -                                   | 1.3                    | 23.5         | 30    |
|              |                   |            |      |      |                   |      |      |                  |     |      | 3.5                                 | 1.3                    | 27.0         | 30    |
| DSG1207L     | 575/3/60          | 2          | 7.0  | 47.8 | 2                 | 0.33 | 0.67 | 1                | 5.0 | 7.2  | -                                   | -                      | 24.4         | 30    |
|              |                   |            |      |      |                   |      |      |                  |     |      | 3.5                                 | -                      | 27.9         | 35    |
|              |                   |            |      |      |                   |      |      |                  |     |      | -                                   | 1.3                    | 25.7         | 30    |
|              |                   |            |      |      |                   |      |      |                  |     |      | 3.5                                 | 1.3                    | 29.2         | 35    |
| DSG1207W     | 575/3/60          | 2          | 7.0  | 47.8 | 2                 | 0.33 | 0.67 | 1                | 5.0 | 7.2  | -                                   | -                      | 24.4         | 30    |
|              |                   |            |      |      |                   |      |      |                  |     |      | 3.5                                 | -                      | 27.9         | 35    |
|              |                   |            |      |      |                   |      |      |                  |     |      | -                                   | 1.3                    | 25.7         | 30    |
|              |                   |            |      |      |                   |      |      |                  |     |      | 3.5                                 | 1.3                    | 29.2         | 35    |
| DSG1503D     | 208/230/3/60      | 2          | 19.2 | 157  | 2                 | 0.5  | 2.7  | 1                | 3.5 | 10.9 | -                                   | -                      | 59.5/59.5    | 70/70 |
|              |                   |            |      |      |                   |      |      |                  |     |      | 9.6/8.7                             | -                      | 69.1/68.2    | 80/80 |
|              |                   |            |      |      |                   |      |      |                  |     |      | -                                   | 3.3/3.0 (2.4)          | 62.8/62.5    | 80/80 |
|              |                   |            |      |      |                   |      |      |                  |     |      | 9.6/8.7                             | 3.3/3.0 (2.4)          | 72.4/71.2    | 90/80 |
| DSG1503L     | 208/230/3/60      | 2          | 19.2 | 157  | 2                 | 0.5  | 2.7  | 1                | 5.0 | 14.5 | -                                   | -                      | 63.1/63.1    | 80/80 |
|              |                   |            |      |      |                   |      |      |                  |     |      | 9.6/8.7                             | -                      | 72.7/71.8    | 90/90 |
|              |                   |            |      |      |                   |      |      |                  |     |      | -                                   | 3.3/3.0 (2.4)          | 66.4/66.1    | 80/80 |
|              |                   |            |      |      |                   |      |      |                  |     |      | 9.6/8.7                             | 3.3/3.0 (2.4)          | 76.0/74.8    | 90/90 |
| DSG1503W     | 208/230/3/60      | 2          | 19.2 | 157  | 2                 | 0.5  | 2.7  | 1                | 5.0 | 14.5 | -                                   | -                      | 63.1/63.1    | 80/80 |
|              |                   |            |      |      |                   |      |      |                  |     |      | 9.6/8.7                             | -                      | 72.7/71.8    | 90/90 |
|              |                   |            |      |      |                   |      |      |                  |     |      | -                                   | 3.3/3.0 (2.4)          | 66.4/66.1    | 80/80 |
|              |                   |            |      |      |                   |      |      |                  |     |      | 9.6/8.7                             | 3.3/3.0 (2.4)          | 76.0/74.8    | 90/90 |
| DSG1504D     | 460/3/60          | 2          | 9.0  | 74.8 | 2                 | 0.5  | 1.4  | 1                | 3.5 | 7.2  | -                                   | -                      | 30.2         | 35    |
|              |                   |            |      |      |                   |      |      |                  |     |      | 4.3                                 | -                      | 34.5         | 40    |
|              |                   |            |      |      |                   |      |      |                  |     |      | -                                   | 1.2 (1.0)              | 31.4         | 40    |
|              |                   |            |      |      |                   |      |      |                  |     |      | 4.3                                 | 1.2 (1.0)              | 35.7         | 40    |
| DSG1504L     | 460/3/60          | 2          | 9.0  | 74.8 | 2                 | 0.5  | 1.4  | 1                | 5.0 | 10.6 | -                                   | -                      | 33.6         | 40    |
|              |                   |            |      |      |                   |      |      |                  |     |      | 4.3                                 | -                      | 37.9         | 45    |
|              |                   |            |      |      |                   |      |      |                  |     |      | -                                   | 1.2 (1.0)              | 34.8         | 45    |
|              |                   |            |      |      |                   |      |      |                  |     |      | 4.3                                 | 1.2 (1.0)              | 39.1         | 45    |
| DSG1504W     | 460/3/60          | 2          | 9.0  | 74.8 | 2                 | 0.5  | 1.4  | 1                | 5.0 | 10.6 | -                                   | -                      | 33.6         | 40    |
|              |                   |            |      |      |                   |      |      |                  |     |      | 4.3                                 | -                      | 37.9         | 45    |
|              |                   |            |      |      |                   |      |      |                  |     |      | -                                   | 1.2 (1.0)              | 34.8         | 45    |
|              |                   |            |      |      |                   |      |      |                  |     |      | 4.3                                 | 1.2 (1.0)              | 39.1         | 45    |
| DSG1507D     | 575/3/60          | 2          | 7.0  | 53.9 | 2                 | 0.5  | 1.0  | 1                | 3.5 | 5.0  | -                                   | -                      | 22.8         | 25    |
|              |                   |            |      |      |                   |      |      |                  |     |      | 3.5                                 | -                      | 26.3         | 30    |
|              |                   |            |      |      |                   |      |      |                  |     |      | -                                   | 1.3                    | 24.1         | 30    |
|              |                   |            |      |      |                   |      |      |                  |     |      | 3.5                                 | 1.3                    | 27.6         | 30    |
| DSG1507L     | 575/3/60          | 2          | 7.0  | 53.9 | 2                 | 0.5  | 1.0  | 1                | 5.0 | 7.2  | -                                   | -                      | 25.0         | 30    |
|              |                   |            |      |      |                   |      |      |                  |     |      | 3.5                                 | -                      | 28.5         | 35    |
|              |                   |            |      |      |                   |      |      |                  |     |      | -                                   | 1.3                    | 26.3         | 30    |
|              |                   |            |      |      |                   |      |      |                  |     |      | 3.5                                 | 1.3                    | 29.8         | 35    |
| DSG1507W     | 575/3/60          | 2          | 7.0  | 53.9 | 2                 | 0.5  | 1.0  | 1                | 5.0 | 7.2  | -                                   | -                      | 25.0         | 30    |
|              |                   |            |      |      |                   |      |      |                  |     |      | 3.5                                 | -                      | 28.5         | 35    |
|              |                   |            |      |      |                   |      |      |                  |     |      | -                                   | 1.3                    | 26.3         | 30    |
|              |                   |            |      |      |                   |      |      |                  |     |      | 3.5                                 | 1.3                    | 29.8         | 35    |

# APPENDIX C UNIT DIMENSIONS

|                     |       |
|---------------------|-------|
| MODEL<br>DSG090-150 |       |
| A                   | 54-58 |

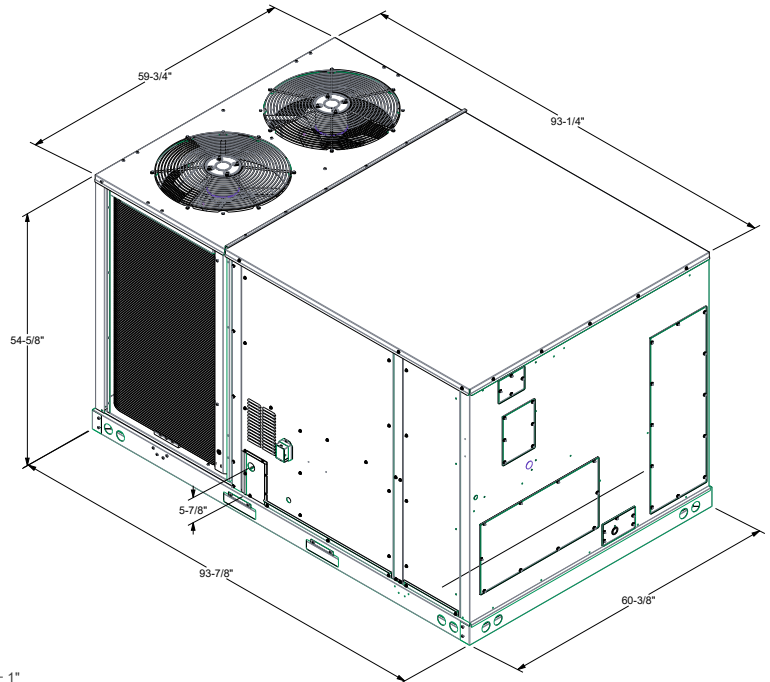
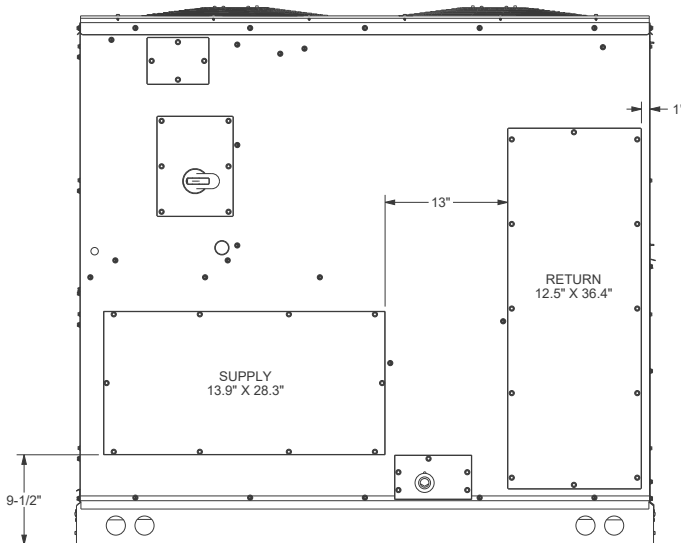

FIGURE 17



HORIZONTAL DISCHARGE

FIGURE 16

## NOTE

For horizontal discharge, remove supply and return duct cover panels from the end of the unit. Save all washed screws. According to the model size, remove (6 or 8) factory supplied panel clips that are secured to the base pan, behind the filter access panel. With the insulated side of the panel facing up, attach the clips. Place the provided gasket material completely around the perimeter of the clip side on both panels. Place the assembled panels over the supply and return duct openings in the base pan and push down to snap panels into place. Ensure the panel is evenly seated on the flanges around the duct openings and the gasket is creating a good seal.

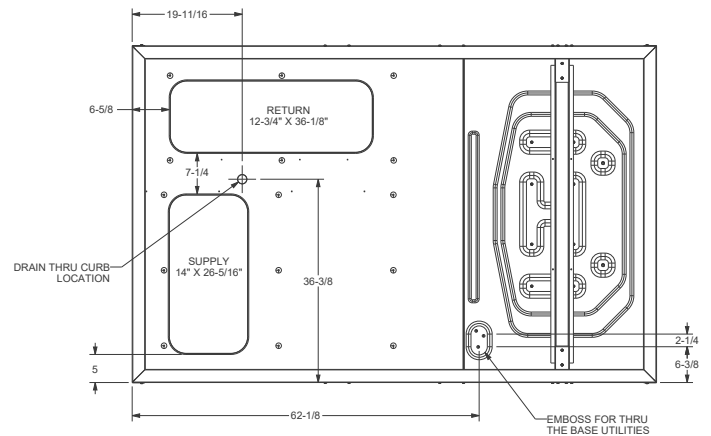

VERTICAL DISCHARGE (TOP VIEW OF UNIT)

FIGURE 15

NOTE: REFER TO IOD-7082 INCLUDED IN THE LITERATURE PACK FOR INSTALLING HORIZONTAL DUCT COVERS.



## APPENDIX D MIN-MAX AIRFLOW

| RECOMMENDED MIN-MAX AIRFLOW RANGE |                          |                         |                         |              |
|-----------------------------------|--------------------------|-------------------------|-------------------------|--------------|
| UNIT                              | HIGH FIRE RATE<br>BTU/HR | HEATING<br>MINIMUM SCFM | COOLING<br>MINIMUM SCFM | MAXIMUM SCFM |
| DSG090                            | 210,000                  | 2250                    | 2360                    | 3690         |
| DSG102                            | 210,000                  | 2550                    | 2680                    | 4230         |
| DSG120                            | 210,000                  | 3000                    | 3150                    | 4860         |
| DSG150                            | 210,000                  | 3750                    | 3940                    | 6070         |

# WIRING DIAGRAM

**WARNING** HIGH VOLTAGE!  
DISCONNECT ALL POWER BEFORE SERVICING OR INSTALLING THIS UNIT. MULTIPLE POWER SOURCES MAY BE PRESENT. FAILURE TO DO SO MAY CAUSE PROPERTY DAMAGE, PERSONAL INJURY OR DEATH.

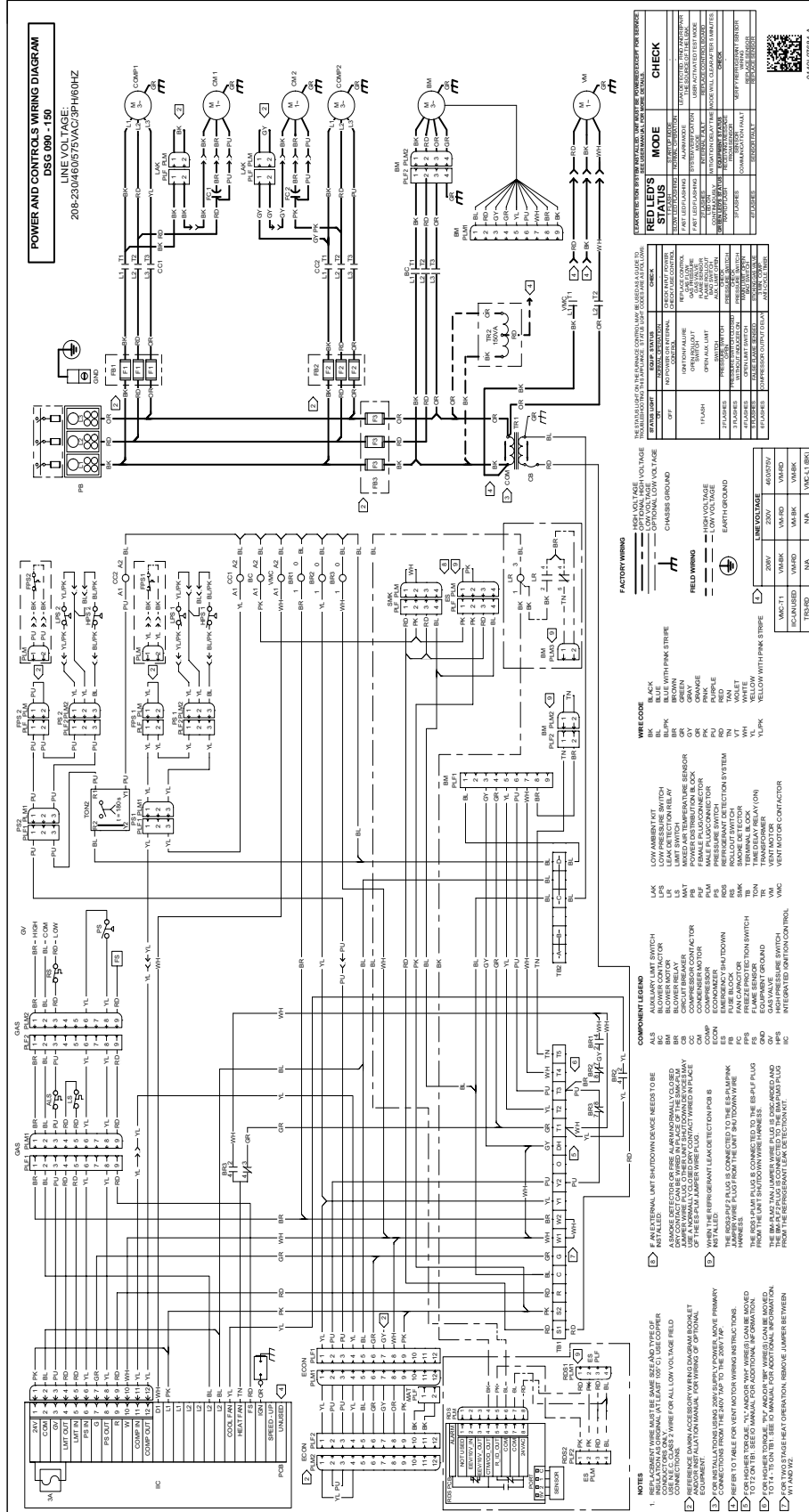

Wiring is subject to change. Always refer to the wiring diagram on the unit for the most up-to-date wiring.



# Start-up Checklist

*\*Store in job file*

Date: \_\_\_\_\_ Location: \_\_\_\_\_  
Model Number: \_\_\_\_\_  
Serial Number: \_\_\_\_\_  
Technician: \_\_\_\_\_ Unit #: \_\_\_\_\_

## Pre Start-Up

*(Check each item as completed)*

- Verify all packaging material has been removed.
- Remove all shipping brackets per installation instructions.
- Verify the job site voltage agrees with the unit serial plate.
- Verify condensate connection is installed per installation instructions.
- Verify proper clearance around the unit for safety, service, maintenance and proper unit operation.
- Verify proper weatherproofing of all ductwork, roof curbs and electrical connections.
- Check that the flue screen is in place.
- Check gas piping for leaks.
- Verify gas pressure to the unit is within the range specified on the serial plate.
- Check to ensure that all fans, pulleys and wheels are secure.
- Check for proper belt tension and alignment per installation instructions.
- Check refrigerant piping for rubbing and leaks. *Repair if necessary.*
- Check unit wiring to ensure it is not in contact with refrigerant piping or sharp metal edges.
- Check all electrical connections and terminals. *Tighten as needed.*
- Verify that the crankcase heaters have been energized for 24 hours.
- Verify the scroll compressor(s) are rotating in the right direction.
- Verify all accessories are installed and operating correctly.
- Check filters and replace if necessary.
- Verify the installation of the thermostat.



# Start-up Checklist

**Start-Up**  
*(Insert the values as each item is completed.)*

## ELECTRICAL

|                           |         |       |         |       |         |       |
|---------------------------|---------|-------|---------|-------|---------|-------|
| Supply Voltage            | L1 - L2 | _____ | L2 - L3 | _____ | L3 - L1 | _____ |
| Circuit 1 Compressor Amps | L1      | _____ | L2      | _____ | L3      | _____ |
| Circuit 2 Compressor Amps | L1      | _____ | L2      | _____ | L3      | _____ |
| Blower Amps               | L1      | _____ | L2      | _____ | L3      | _____ |
| Condenser Fan Amps        | Fan 1   | _____ | Fan 2   | _____ | Fan 3   | _____ |

## BLOWER EXTERNAL STATIC PRESSURE

|                                |       |          |
|--------------------------------|-------|----------|
| Return Air Static Pressure     | _____ | IN. W.C. |
| Supply Air Static Pressure     | _____ | IN. W.C. |
| Total External Static Pressure | _____ | IN. W.C. |
| Blower Wheel RPM               | _____ | RPM      |

## TEMPERATURES

|                                |       |    |       |    |
|--------------------------------|-------|----|-------|----|
| Outdoor Air Temperature        | _____ | DB | _____ | WB |
| Return Air Temperature         | _____ | DB | _____ | WB |
| Cooling Supply Air Temperature | _____ | DB | _____ | WB |
| Heating Supply Air Temperature | _____ | DB | _____ |    |

## PRESSURES

|                            |       |                     |                            |
|----------------------------|-------|---------------------|----------------------------|
| Gas Inlet Pressure         | _____ | IN. W.C.            |                            |
| Gas Manifold Pressure      | _____ | IN. W.C. (Low Fire) | _____ IN. W.C. (High Fire) |
| Suction Circuit 1          | _____ | PSIG                | _____ °F                   |
| Superheat (Orifice System) |       |                     | _____ °F                   |
| Suction Circuit 2          | _____ | PSIG                | _____ °F                   |
| Superheat (Orifice System) |       |                     | _____ °F                   |
| Discharge Circuit 1        | _____ | PSIG                | _____ °F                   |
| Subcooling (TXV System)    |       |                     | _____ °F                   |
| Discharge Circuit 2        | _____ | PSIG                | _____ °F                   |
| Subcooling (TXV System)    |       |                     | _____ °F                   |

## (HEAT PUMP ONLY)

|                     |       |      |          |
|---------------------|-------|------|----------|
| Suction Circuit 1   | _____ | PSIG | _____ °F |
| Suction Circuit 2   | _____ | PSIG | _____ °F |
| Discharge Circuit 1 | _____ | PSIG | _____ °F |
| Discharge Circuit 2 | _____ | PSIG | _____ °F |

**PAGE LEFT INTENTIONALLY BLANK**

**PAGE LEFT INTENTIONALLY BLANK**

**PAGE LEFT INTENTIONALLY BLANK**

**CUSTOMER FEEDBACK**

Daikin is very interested in all product comments. Please fill out the feedback form on the following link:  
<https://daikincomfort.com/contact-us>

You can also scan the QR code on the right to be directed to the feedback page.



**PRODUCT REGISTRATION**

Thank you for your recent purchase. Though not required to get the protection of the standard warranty, registering your product is a relatively short process, and entitles you to additional warranty protection, except that failure by California and Quebec residents to register their product does not diminish their warranty rights. The duration of warranty coverages in Texas and Florida differs in some cases.

For Product Registration, please register by following this link:  
<https://daikincomfort.com/owner-support/product-registration>

You can also scan the QR code on the right to be directed to the Product Registration page.



Our continuing commitment to quality products may mean a change in specifications without notice.

©2024 **DAIKIN COMFORT TECHNOLOGIES MANUFACTURING, L.P.**

19001 Kermier Rd., Waller, TX 77484

[www.daikincomfort.com](http://www.daikincomfort.com)